

SUBMITTAL SHEET
HUH SERIES
**INDUSTRIAL
UNIT HEATER**

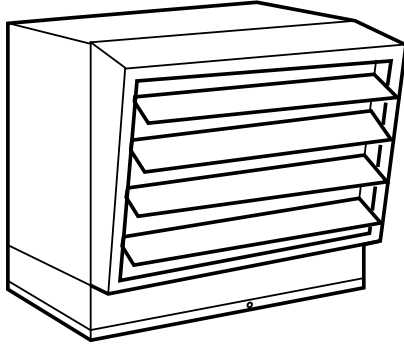

CAPACITIES
5, 7.5, 10, 15, 20, 25, 30 KW
208, 240, 480, 600V

See Selection Chart for all Options

HUH SERIES - INDUSTRIAL UNIT HEATER

JOB NAME: _____

LOCATION: _____

ARCHITECT: _____

ENGINEER: _____

CONTRACTOR: _____

SUBMITTED BY: _____ DATE: _____

TAG/ITEM	QTY.	CATALOG NUMBER	HEATER			AMPS	CONTROL CKT. MOTOR VOLTS	MOTOR VOLTS	AIR FLOW		THROW	BUILT-IN CNTRL.
			KW	VOLTS	Ø				CFM	F° RISE		

ACCESSORIES AND CONTROLS	TAG/ITEM	QTY.	CATALOG NUMBER	DESCRIPTION

SUBMITTED BY:	DATE

APPROVED BY:	DATE

HUH SERIES ARCHITECT'S AND ENGINEER'S SPECIFICATIONS*

Furnish and install where indicated on plans, electric unit heaters suitable for small and large areas and UL and CUL listed for wall or ceiling mounting.

The cabinet shall be made of 22 gauge steel, welded, and phosphate coated to resist corrosion. Side, front, and back panels shall be removable without dismantling the heater by removing four screws from inside the control compartment, thus permitting full access to the elements and fan motor areas. Individual adjustable louvers with 30 degree downward stops shall be furnished to provide desired control of discharge air. The control compartment shall be located at the bottom of the cabinet and provided with a swing down hinged cover to permit full access for cleaning and servicing without dismantling the heater. All heater and control wiring shall terminate inside the control compartment. The heater shall be provided with combination wall/ceiling bracket for 5.0 KW and 7.5 KW units and shall have capability of full horizontal and vertical positions. The cabinet shall be finished in a beige polyester powder paint.

The heating elements shall be of the non-glowing design consisting of 80/20 nickel-chromium resistance wire, embedded in magnesium oxide and enclosed in a metal sheath to which metal plated fins are copper brazed. The elements shall be painted with aluminized paint for corrosion resistance and cover the entire discharge area for uniform heating. The heating elements shall be warranted for five years.

The fan motor shall be totally enclosed, permanently lubricated, impedance protected, and of unit bearing design suitable for horizontal or vertical operation with high starting and running torques. (5.0 & 7.5 KW units) The fan motor shall be totally enclosed, permanently lubricated, thermal protected, and of double bearing design with high starting and running torques. (10-30 KW units) The fan blade shall be aluminum and directly connected to the fan motor, designed specifically for unit heater application.

The fan control shall be of the bimetallic snap-action type and shall activate fan motor after heating elements reach operating temperature and continue to operate the fan motor after thermostat is satisfied and until the heating elements cool.

A thermal cutout shall be built into the system to automatically shut off the heater in the event of overheating and reactivate when temperature returns to normal.

The heater shall be provided with a factory installed, heavy duty, 3-pole contactor providing quiet, efficient operation, making external contacts and additional wiring unnecessary.

Heaters shall be IUH Series as manufactured by Berko, a division of Marley Engineered Products, Bennettsville, SC.

*Berko reserves the right to change specifications without prior notice.

Models & Specifications:

ITEM INFORMATION		ELECTRICAL DATA						
CATALOG NO.	UPC	KW	BTU/HR.	VOLTAGE	PHASE	MAX AMPERAGE 3 PHASE	CFM	WEIGHT
HUH520SA	685360038612	5**	17	208	1-3	12.5	270	26 lbs
HUH548SA	685360038933	5**	17	480	1-3	6	270	31 lbs
HUH724SA	685360039121	7.5**	25.6	240	1-3	18.1	270	27 lbs
HUH748SA	685360039268	7.5**	25.6	480	1-3	9	270	31 lbs
HUH1020	685360037073	10	34.1	208	1-3	27.8	500	72 lbs
HUH1024M	685360037134	10	34.1	240	1-3	25.7	500	62 lbs
HUH1048M	685360037233	10	34.1	480	1-3	12.8	500	72 lbs
HUH1520M	685360037417	15	51.2	208	1-3	42	750	78 lbs
HUH1524M	685360037448	15	51.2	240	1-3	37.7	750	68 lbs
HUH1548M	685360037547	15	51.2	480	1-3	18.8	750	78 lbs
HUH2048M	685360037769	20	68.2	480	1-3	24.8	1000	78 lbs
HUH3048L	685360038186	30	102.2	480	3	36.9	1800	142 lbs
HUH524SA	685360038711	5**	17	240	1-3	13.8	270	26 lbs
HUH2548L	685360038063	25	85.2	480	3	31.1	1300	136 lbs
HUH560SA	685360039039	5**	17	600	3	4.8	270	31 lbs
HUH760SA	685360039374	7.5**	25.6	600	3	7.2	270	31 lbs
HUH1060M	685360037295	10	34.1	600	3	9.6	500	72 lbs
HUH1560M	685360037653	15	51.2	600	3	14.5	750	80 lbs
HUH2060M	685360037813	20	68.2	600	3	19.3	1000	80 lbs
HUH2560L	685360038131	25	85.2	600	3	24	1300	142 lbs
HUH3060L	685360038223	30	102.2	600	3	28.9	1800	142 lbs

**5 kW and 7.5 kW can be used in horizontal or vertical position. Heaters come equipped with ceiling mounting bracket for horizontal or vertical flow mounting or any position between.

Optional Accessories:

CATALOG NO.	UPC	DESCRIPTION	SHIP WT.
CWB1A	685360018201	Combination wall/ceiling bracket for 5KW thru 15KW units	4 lbs
CWB2A	685360152400	Same as above but for 20KW thru 50KW units	14 lbs
UHTA1	685360152431	Single-Pole Thermostat kit 60-120°F temp. range for field installation in all units	1 lbs
DS30*	685360019956	3-pole power disconnect switch kit for field installation on all horizontal unit heaters rated 24 amps or less.	1 lbs
DS63*	685360019963	3-pole power disconnect switch kit for field installation on all horizontal unit heaters 10KW and above rated 24 to 50 amps.	1 lbs
SW	685360036724	Summer-Winter Fan Switch Kit. Field installed. Provides summer fan operation.	1 lbs

No matter the industry or application, Marley Engineered Products has a robust portfolio of innovative, reliable, high-performance comfort heating and ventilation solutions for all your heating needs.

For more information or assistance on your next project, contact Technical Services at 800-642-4328

Dimensions and Clearances:

KW Size	A	B	C	D	E	F
5-7.5	14"	12 1/2"	12 3/8"	5 1/2"	13"	1 3/4"
10-20	18"	18"	17 1/2"	9 1 1/2"	*	2"
25-30	26"	24"	23 1/8"	9 1 1/2"	20"	2"

KW Size	G	H	I	J
5-7.5	1 3/8"	1 1/2"	(2) 1/2", 3/4"	1/2"
10-20	2 1/2"	2 1/4"	(2) 3/4", 1"	(3) 1", 1 1/4", 1 1/2"
25-30	2 3/4"	2 1/4"	(2) 1", 1 1/2"	(3) 1", 1 1/2", 2"

*13 in. for 10-15 kW units; 16 in. for 20 kW unit. 5 kW and 7.5 kW can be used in horizontal or vertical position. Heaters come equipped with ceiling mounting bracket for horizontal or vertical flow mounting or any position between.

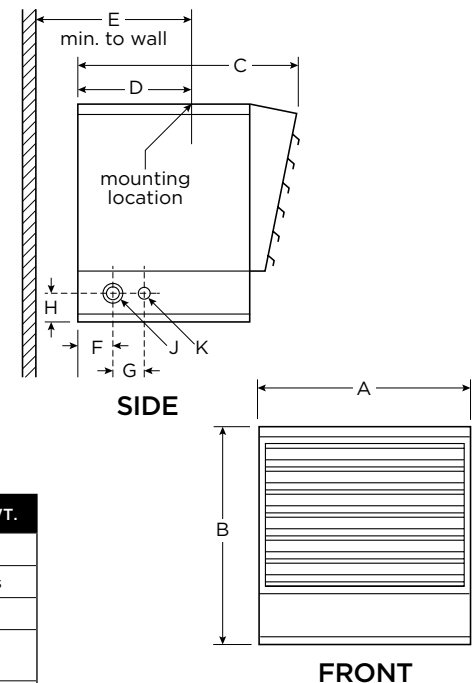

SIDE

FRONT

Scan the QR code to access additional specs and features



Approvals: _____