

**WASHDOWN CORROSION-RESISTANT UNIT HEATER**

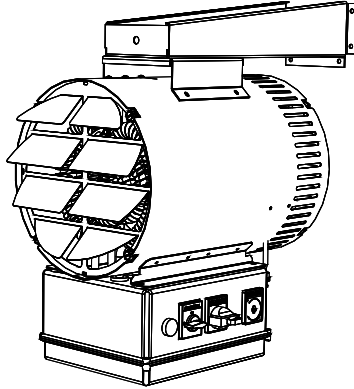

**CAPACITIES**

2.0-47 kW | 120-600V  
1Ø or 3Ø

Thermostat Range: 40°-120° F  
Air Movement: 700-2400 CFM

See Selection Chart for Options

JOB NAME: \_\_\_\_\_

LOCATION: \_\_\_\_\_

ARCHITECT: \_\_\_\_\_

ENGINEER: \_\_\_\_\_

CONTRACTOR: \_\_\_\_\_

SUBMITTED BY: \_\_\_\_\_ DATE: \_\_\_\_\_

TAG/ITEM	QTY.	CATALOG NUMBER	HEATER			AMPS	BUILT-IN CONTROL	AIR MOVEMENT		
			KW	VOLTS	Ø			CFM	THROW	TEMP. RISE

ACCESSORIES AND CONTROLS	TAG/ITEM	QTY.	CATALOG NUMBER	DESCRIPTION

SUBMITTED BY:	DATE

APPROVED BY:	DATE

BWD SERIES - WASHDOWN CORROSION-RESISTANT UNIT HEATER

# **BWD SERIES** ARCHITECT'S AND ENGINEER'S SPECIFICATIONS\*

Wash-down, corrosion resistant unit heater(s) shall be supplied by Berko®, a Marley Engineered Products® Brand, Bennettsville, SC, USA, and shall be of the KW rating, voltage and phase specified in the schedule. They shall be fan-forced type heating units, certified to cULus and ABS, and listed for corrosive areas and NEMA4X wash-down requirements.

**SAFETY:** Built in over temperature protection shall be provided by an automatic reset thermal cutout.

**HEAT EXCHANGER:** The heating elements shall be industrial grade, Type 316 corrosion resistant stainless steel sheathed with stainless steel fins for maximum heat dissipation. The elements are to be attached to junction box with leak resistant stainless steel fittings. Optional monel finned tubular elements available.

**ENCLOSURE:** Heating elements and motor are enclosed in a round, heavy 16-gauge 304 stainless steel shroud for corrosion resistance and assembled with stainless steel hardware. All controls are located in a NEMA 4X molded fiberglass control enclosure mounted beneath the heater cabinet. Optional epoxy painted parts available.

**FAN MOTOR ASSEMBLY:** The fan and motor assembly shall include a totally enclosed, permanently lubricated, ball bearing UL recognized motor, epoxy coated for corrosion resistance. The fan

shall be aluminum with corrosion resistant coating, directly connected to the motor, and be dynamically balanced. An epoxy sealed thermal fan delay shall be provided to allow the fan to continue to operate after heating thermostat has been satisfied to maximize transfer of generated heat to space being heated. Adjustable, stainless steel, louvered outlet grille can be rotated 90° to direct airflow up, down, left or right. Heavy gauge, 304 stainless steel rear grille protects against accidental contact with the fan blade.

**MOUNTING:** The heater comes complete with a 304 stainless steel swivel mounting bracket which can be used either for wall or ceiling mounting. Four field-supplied 3/8-16 threaded rods can also be used for ceiling installation on specific units.

**OPTIONAL BUILT-IN CONTROLS:** The controls are completely factory prewired and tested and enclosed in a non-metallic NEMA4X box. This control center shall include automatic reset over-temperature protector, contactors, fan delay relay, motor contactor and fused transformer for 24V control circuit. Convenient terminal blocks are included for remote thermostat connection. Optional factory installed offering includes an adjustable thermostat—single and two stage, pilot light, heat/fan selector switch, disconnect switch, 120v control circuit, and a manual reset.

*\*Berko reserves the right to change specifications without prior notice.*

**Models & Specifications:**

ITEM INFORMATION	ELECTRICAL DATA				MOTOR			AIR FLOW			2-STAGE CONTROL	SHIP WT.	
	CATALOG NO.	VOLTS	PHASE	TOTAL AMPS*	KW	HP	VOLTS	PHASE	RISE**	CFM			THROW
BWD02112	120	1	16.7	2.0	—	120	1	9°F	700	—	—	60 lbs	
BWD02812	208	1	9.6		—	208	1	9°F	700	—	—	60 lbs	
BWD02212	240	1	8.3		—	240	1	9°F	700	—	—	60 lbs	
BWD03112	120	1	25	3.0	—	120	1	14°F	700	—	—	60 lbs	
BWD03812	208	1	14.4		—	208	1	14°F	700	—	—	60 lbs	
BWD03212	240	1	12.5		—	240	1	14°F	700	—	—	60 lbs	
BWD03712	277	1	10.8		—	277	1	14°F	700	—	—	60 lbs	
BWD03832	208	3	8.3		—	208	1	14°F	700	—	—	60 lbs	
BWD03232	240	3	7.2		—	240	1	14°F	700	—	—	60 lbs	
BWD03432	480	3	3.6	5.0	—	480	1	14°F	700	—	—	60 lbs	
BWD05812	208	1	24		—	208	1	23°F	700	—	—	60 lbs	
BWD05212	240	1	20.8		—	240	1	23°F	700	—	—	60 lbs	
BWD05712	277	1	18.1		—	277	1	23°F	700	—	—	60 lbs	
BWD05412	480	1	10.4		—	480	1	23°F	700	—	—	60 lbs	
BWD05832	208	3	13.9		—	208	1	23°F	700	—	—	60 lbs	
BWD05232	240	3	12		—	240	1	23°F	700	—	—	60 lbs	
BWD05432	480	3	6		—	480	1	23°F	700	—	—	60 lbs	
BWD07812	208	1	36.1		7.5	—	208	1	34°F	700	—	—	60 lbs
BWD07212	240	1	31.3			—	240	1	34°F	700	—	—	60 lbs
BWD07712	277	1	27.1	—		277	1	34°F	700	—	—	60 lbs	
BWD07412	480	1	15.6	—		480	1	34°F	700	—	—	60 lbs	
BWD07832	208	3	20.8	—		208	1	34°F	700	—	—	60 lbs	
BWD07232	240	3	18	—		240	1	34°F	700	—	—	60 lbs	
BWD07432	480	3	9	10	—	480	1	34°F	700	—	—	60 lbs	
BWD10212	240	1	41.7		—	240	1	22°F	1450	—	—	60 lbs	
BWD10712	277	1	36.1		—	277	1	22°F	1450	—	—	60 lbs	
BWD10412	480	1	20.8		—	480	1	22°F	1450	—	—	60 lbs	
BWD10832	208	3	27.8		—	208	1	22°F	1450	—	—	60 lbs	
BWD10232	240	3	24.1		—	240	1	22°F	1450	—	—	60 lbs	
BWD10432	480	3	12		—	480	1	22°F	1450	—	—	60 lbs	
BWD12812	208	1	60.1		12.5	—	208	1	27°F	1450	—	—	60 lbs
BWD12212	240	1	52.1			—	240	1	27°F	1450	—	—	60 lbs
BWD12832	208	3	34.7			—	208	1	27°F	1450	—	—	60 lbs
BWD12232	240	3	30.1	—		240	1	27°F	1450	—	—	60 lbs	
BWD12432	480	3	15	—		480	1	27°F	1450	—	—	60 lbs	
BWD-234-U11L-0150I	347	1	47	15		¼	347	1	21°F	2400	50'	1A	130 lbs
BWD-234-U11L-0150D	208	3	44		¼	208	1	21°F	2400	50'	1A	130 lbs	
BWD-234-U11L-0150K	240	3	39		¼	240	1	21°F	2400	50'	1A	130 lbs	
BWD-234-U11L-0150U	480	3	20		¼	480	1	21°F	2400	50'	1A	130 lbs	
BWD-234-U11L-0150Z	600	3	16		¼	600	1	21°F	2400	50'	1A	130 lbs	
BWD-234-U11L-0200U	480	3	26		20	¼	480	1	28°F	2400	50'	1A	130 lbs
BWD-234-U11L-0200Z	600	3	21	¼		600	1	28°F	2400	50'	1A	130 lbs	
BWD-234-U11A-0250U	480	3	32	25	¼	480	1	35°F	2400	50'	1B	130 lbs	
BWD-234-U11A-0250Z	600	3	26		¼	600	1	35°F	2400	50'	1B	130 lbs	
BWD-234-U11A-0300U	480	3	38	30	¼	480	1	42°F	2400	50'	1B	130 lbs	
BWD-234-U11A-0300Z	600	3	31		¼	600	1	42°F	2400	50'	1B	130 lbs	
BWD-234-U11A-0350U	480	3	44	35	¼	480	1	48°F	2400	50'	1B	130 lbs	
BWD-234-U11A-0350Z	600	3	35		¼	600	1	48°F	2400	50'	1B	130 lbs	
BWD-234-U11A-0390U	480	3	48	38.4	¼	480	1	54°F	2400	50'	1B	130 lbs	
BWD-234-U11A-0390Z	600	3	38		¼	600	1	54°F	2400	50'	1B	130 lbs	
BWD-234-U11A-0470Z	600	3	47	47	¼	600	1	64°F	2400	50'	1B	130 lbs	

Note: Stock heaters ordered with custom options subject to longer delivery. \*Total Amps = Heating element and motor amps. \*\*Approximate air temperature rise. 2-Stage heaters can be field wired as single stage. 1A = Optional 2-stage control, unbalanced (option 'X'). 1B = Optional 2-stage control, balanced (option 'X')

**Factory Built-in Options – 2kW-12.5kW Models:**

SUFFIX	DESCRIPTION
T	Thermostat
L	Pilot Light
S	Selector Switch
D	Disconnect Switch
M	Manual Reset
P	Epoxy Coating

NOTE: Monel elements are subject to longer lead times. Please contact factory for details. All units other than standard models are non-returnable.

**Factory Built-in Options – 15kW-47kW Models:**

CATALOG NO.	DESCRIPTION
B	Delete swivel mounting bracket. Heater installs from the ceiling with field furnished threaded rods
D	Power disconnect switch
F8	Fan motor fusing with disconnecting contactor
L	"Heater on" pilot light
M	Secondary manual reset overtemperature cutout. Required for U.S. Coast Guard and ABS Approved designs
S	Three-position selector switch (heater-standby-fan)
T	1-Stage Built-in thermostat 40° to 100° F
	2-Stage Built-in thermostat 40° to 120° F. <i>Must be installed with 2-Stage Control, X</i>
V	120 volt control circuit
X	2-Stage Control

**Remote Room Thermostat:**

CATALOG NO.	SWITCH TYPE	TYPE	RATING	TEMP RANGE	TAMPERPROOF	THERMOMETER	AMPS	PILOT DUTY	COMPATIBILITY
WT11A	Positive snap action switch	SPDT	NEMA 4X rated	40°F-110°F	No	No	25A @ 120-277V	125VA	2kW-12.5kW
1004328	Bulb	SPDT	NEMA 4X	40°-110°F	No	No	25A @ 120-240V 22A @ 277V	125VA	15kW-47kW
1026347	2-Stage Bulb	2 SPDT	NEMA 4X	40°-100°F	No	No	25A @ 120-240V 22A @ 277V	125VA	

# BWD SERIES

## Dimensions and Clearances: 2kW-12.5kW Models

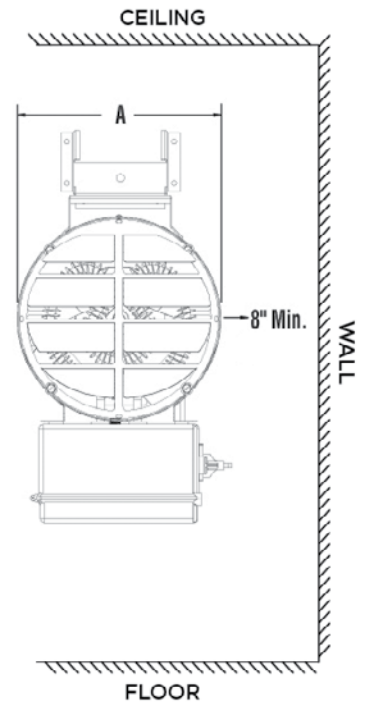
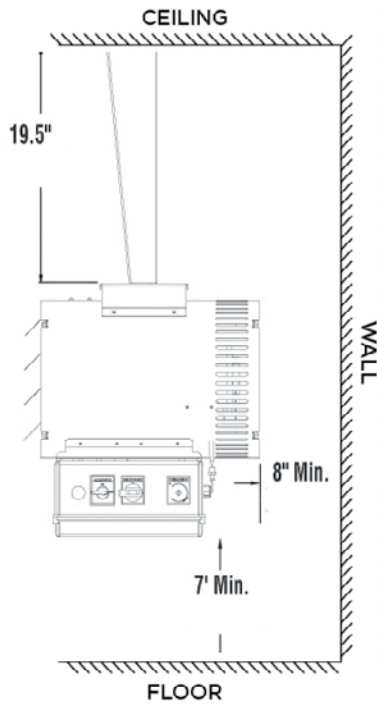
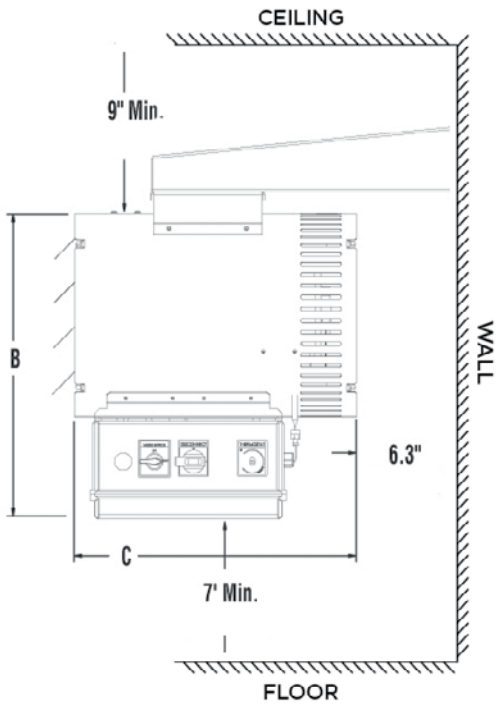

KW	A	B	C	D
2-10	13"	19 1/2"	18"	19 1/2"
12.5	20"	31"	27"	24 1/8"

## Dimensions and Clearances: 15kW-47kW Models

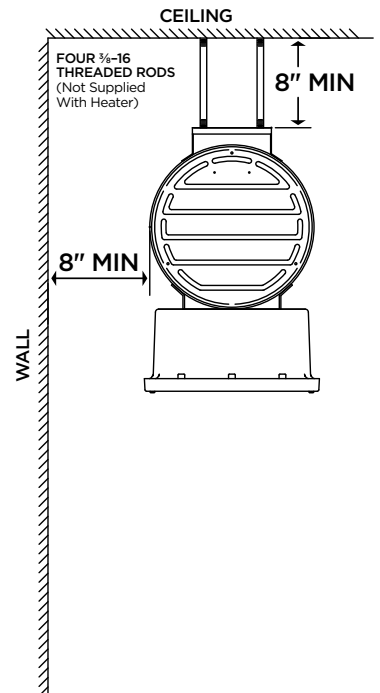
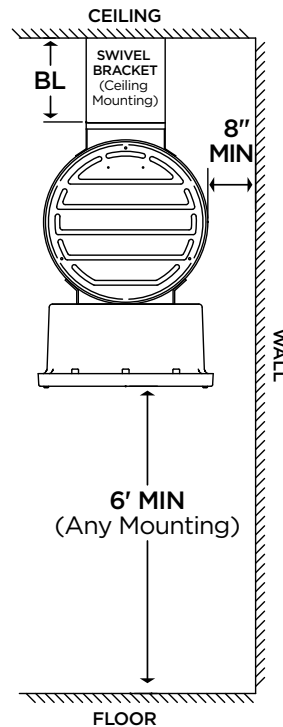
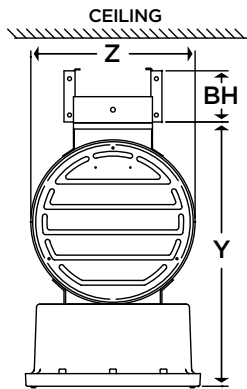
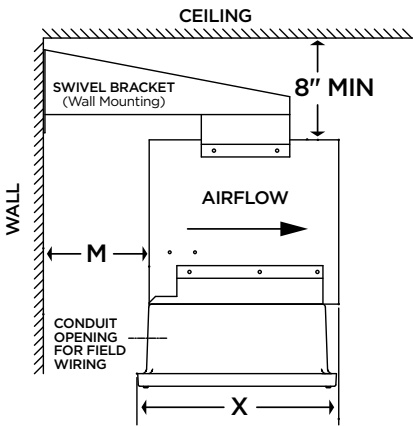

OVERALL			MOUNTING HOLES		
X	Y	Z	BH	BL	M
24 1/2"	26"	20"	7 1/8"	22 1/4"	5"

Approvals: \_\_\_\_\_

# BWD SERIES

## How to Order: 2kW-12.5kW

Example:

**BWD 05 4 3 2 C T L S D 0 0 0**

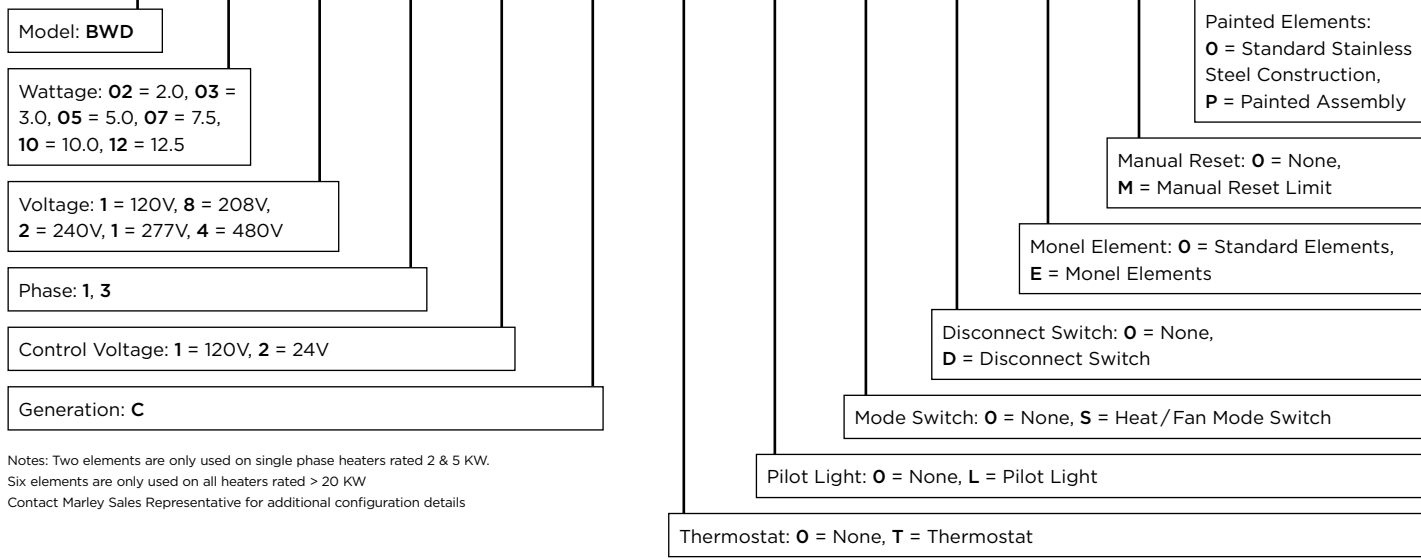

Notes: Two elements are only used on single phase heaters rated 2 & 5 KW.  
 Six elements are only used on all heaters rated > 20 KW  
 Contact Marley Sales Representative for additional configuration details

## How to Order: 15kW-47kW

Example:

**BWD - 234 - U11 R - 0050 T - ELST**

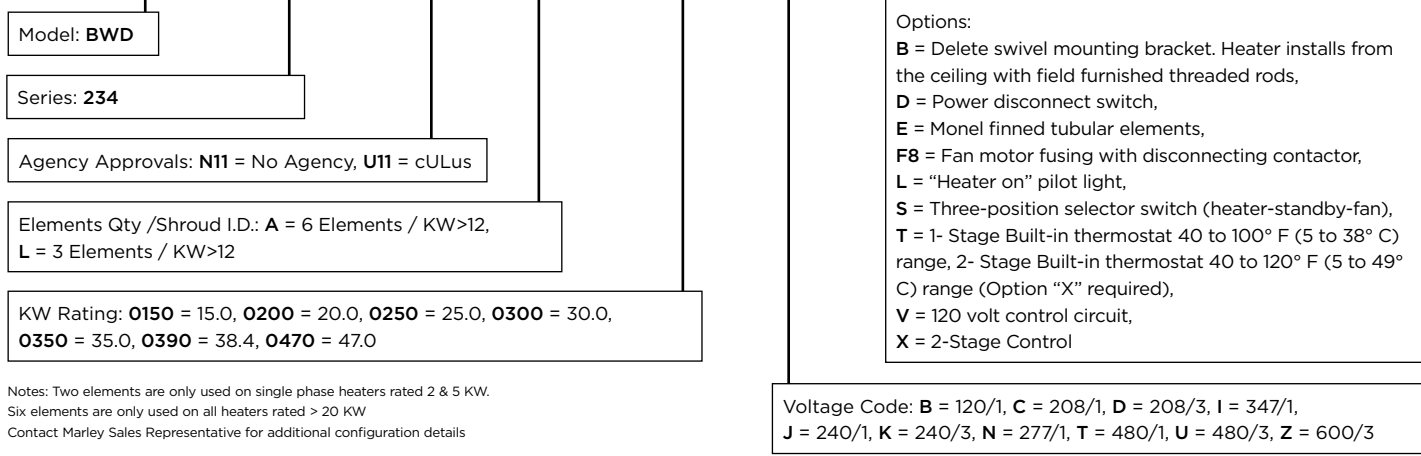

Notes: Two elements are only used on single phase heaters rated 2 & 5 KW.  
 Six elements are only used on all heaters rated > 20 KW  
 Contact Marley Sales Representative for additional configuration details

No matter the industry or application, Marley Engineered Products has a robust portfolio of innovative, reliable, high-performance comfort heating and ventilation solutions for all your heating needs.

For more information or assistance on your next project, contact Technical Services at 800-642-4328

Scan the QR code to access additional specs and features



Approvals: \_\_\_\_\_