

MEP-HT-IPC-1

Installation Instructions

Power Connection Kit with Junction Box for Single Heating Cable.

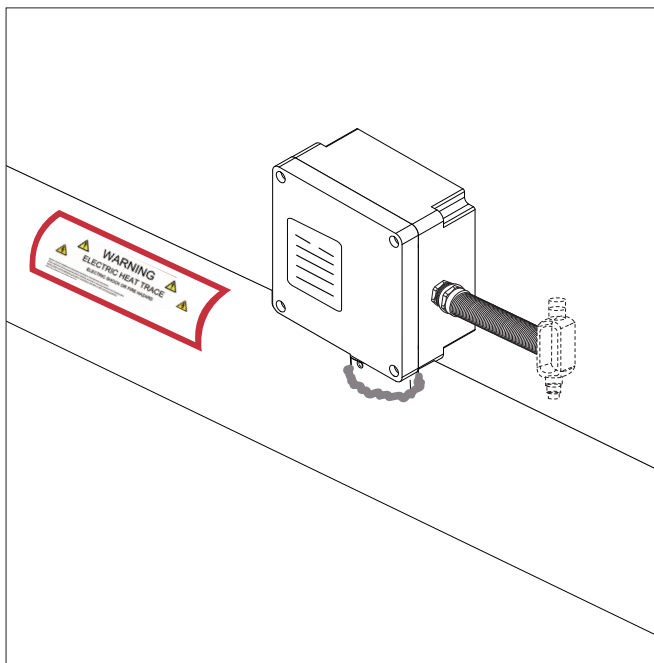

Description

- MEP-HT-IPC-1 is an above-insulation power connection kit for use with Marley Engineered Products QM-CRGX, BK-CRGX, QM-LSRX, BK-LSRX, QM-MSRX, BK-MSRX and QM-HSRX, BK-HSRX self-regulating heating cables.
- MEP-HT-IPC-1 has one 3/4" through-hole for 3/4" conduit and fittings.
- This kit can be utilized to connect power to one heating cable, and can be used for splice of two heating cables and end termination if the through hole is blocked with sealing plug kit.
- MEP-HT-IPC-1 Series employs terminal blocks that accommodate a maximum conductor size of 8AWG* for fine-stranded conductors.

*If a maximum conductor size of 6AWG is required, please contact Marley Engineered Products for larger terminal blocks.

Approvals

MEP-HT-IPC-1



FM26US0013X, FM26CA0003X

Hazardous (classified) locations,
indoors and outdoors

Class I, Division 2, Groups A, B, C and D T*;

Class II/III, Division 2, Groups F and G T*;

Class I, Zone 1, AEx/Ex eb IIC T* Gb;

Zone 21, AEx/Ex tb IIIC T* °C Db;

Type 4X, IP66

Ta = -40°C to +55°C

- T* = For T-rating, please refer to cable documentation.

Kit Contents

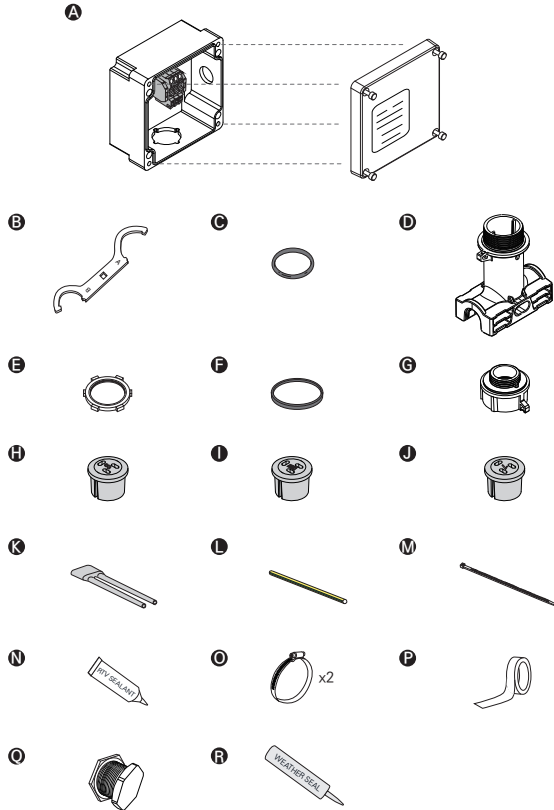

Item	Description	Qty.
A	Junction Box Assembly	1
B	Wrench	1
C	Stand O-Ring	1
D	Pipe Stand	1
E	Lock Nut	1
F	Square-Ring for Compression Cap	1
G	Compression Cap	1
H	S Grommet for a*-CRGX-CT, a*-LSRX-CT, a*-MSRX	1
I	M Grommet for a*-CRGX-CR, a*-LSRX-CR	1
J	L Grommet for a*-HSRX	1
K	Core Sealer	1
L	Insulation Tube (Y/G)	1
M	Cable Tie	1
N	RTV Sealant	1
O	Pipe Strap (Sold Separately)	2
P	Fixing Tape (Sold Separately)	1
Q	Sealing Plug (Sold Separately)	1
R	Weather Seal (Sold Separately)	1

· a* = "QM" for QMARK, or "BK" for BERKO

Tools Required

- Wire cutters
- Marking pen
- Adjustable pliers
- Needle nose pliers
- Utility knife
- Large slotted screwdriver
- 3/16" (or 5mm) hex key

Additional Materials Required

- Sealing Plug Kit if MEP-HT-IPC-1 is used for splice, tee, and end termination.

- Pipe Straps

Model	Pipe Size	Unit Qty.
HTPS-6	Up to 6" Outer Diameter	1 each
HTPS-10	Up to 10" Outer Diameter	1 each

- Small Pipe Adapter

For installation on small pipes (<1" or 25mm diameter), contact Marley Engineered Products for small pipe adapter, model HTSPA-1.

- Fixing Tapes

- HTFT-1 Fiberglass Tape: 3/8" x 66ft. roll
- HTAT-1 Aluminum Tape: 2" x 180ft. roll

User Provided Materials

- Weather seal, conduit, fittings and conduit drain

CAUTION

- The minimum installation temperature is -40°F (-40°C). For more convenient installation, we recommend performing the installation at a temperature above freezing. Store the kit at a temperature above freezing until installation.

WARNING

- Marley Engineered Products heat-tracing systems must be installed correctly to ensure proper operation and to prevent shocks and fires. Pay attention to warnings and carefully follow applicable installation instructions.
- For two or more heating cables powered by a single circuit, the total length of all heating cables should not exceed the maximum circuit length allowed in the chart published in the Marley Engineered Products self-regulating heating cables datasheets or design guide. Additionally, the total current of all heating cables should not surpass 80% of the circuit breaker rating.
- **Electrical Shock or Fire Hazard** : Follow Marley Engineered Products requirements and comply with NEC, CEC, and all relevant local codes.
Ground-fault equipment protection set at 30 mA must be used on each heating cable branch circuit. Arcing may not be stopped by conventional circuit breakers.
- Use wire rated for a temperature of at least 80°C, which is 5° C above the rated service temperature.
- The approvals and performance of the heat tracing systems are based exclusively on the use of specified parts. It is imperative that parts are not substituted and electrical tape is not used.
- Damaged bus wires have the potential to overheat or cause short circuits. When scoring the jacket or core, it is essential to avoid breaking the bus wire strands.
- Both components and cable ends must be kept dry before and throughout the installation process.

- The potential for bus wires to overheat or short circuit exists if the bus wire strands are broken while preparing the cable for connection. Reuse of grommets or use of the wrong grommet can result in leaks, cracked components, shocks, or fires. Ensure the type or opening size of grommet is correct for the heating cable being installed. A new grommet is recommended whenever the cable has been pulled out of the component.
- Before and during installation or servicing, all power circuits must be de-energized.
- Read the MSDS for RTV and components carefully.
- Use thermal insulation and attachment tape suitable for the specific application and heat-tracing temperature. Do not secure heating cables with metal straps or wire, as this may damage the cables.

Specific Conditions of Use

- Marley Engineered Products MEP-HT-IPC-1 Series Connection Kits must be installed using Marley Engineered Products QM-CRGX, BK-CRGX, QM-LSRX, BK-LSRX, QM-MSRX, BK-MSRX and QM-HSRX, BK-HSRX Series Heating Cables.
- Refer to the installation instructions to reduce the potential of an electrostatic charging hazard on the enclosures of the connection kits.
- The end-user shall mount the equipment per instructions.
- To use this kit for splice connection or end termination, Marley Engineered Products Sealing Plug Kit must be purchased separately.

MEP-HT-IPC-1 Kit

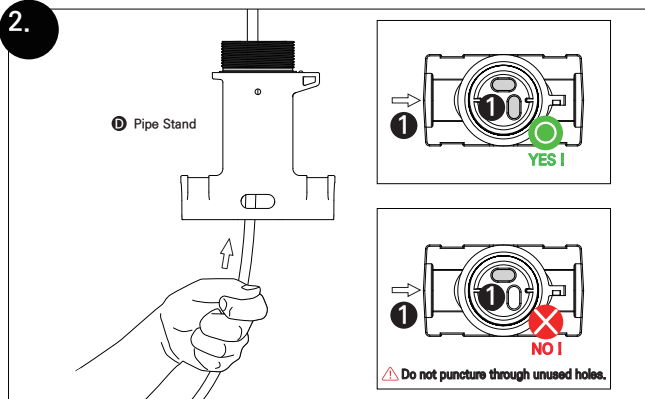
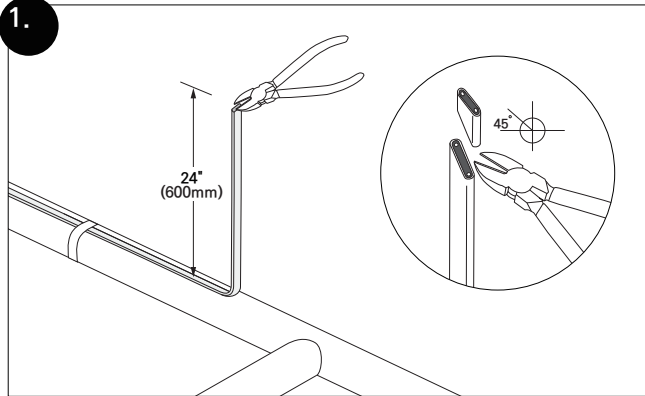

MEP-HT-IPC-1 Kit

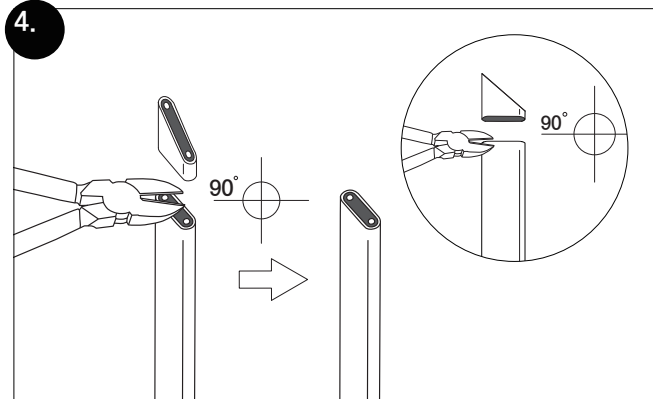
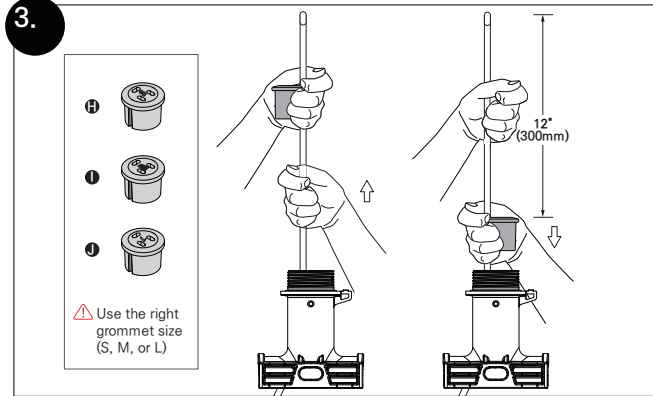

Heating Cable

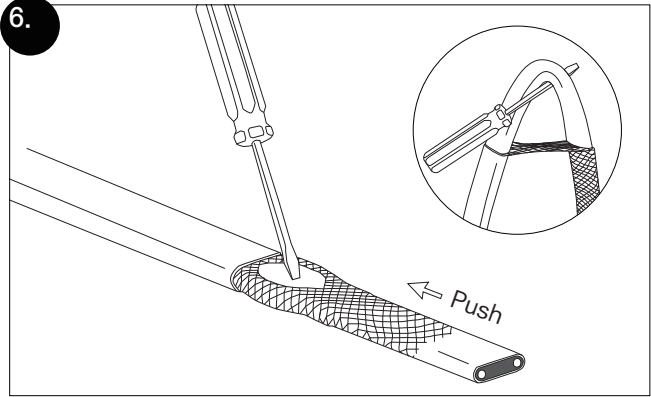
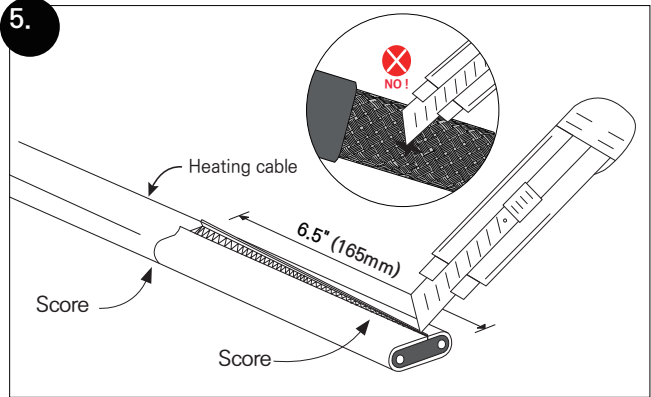

Heating Cable

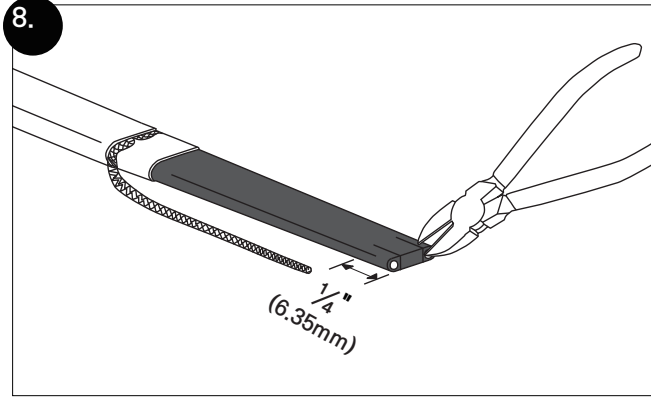
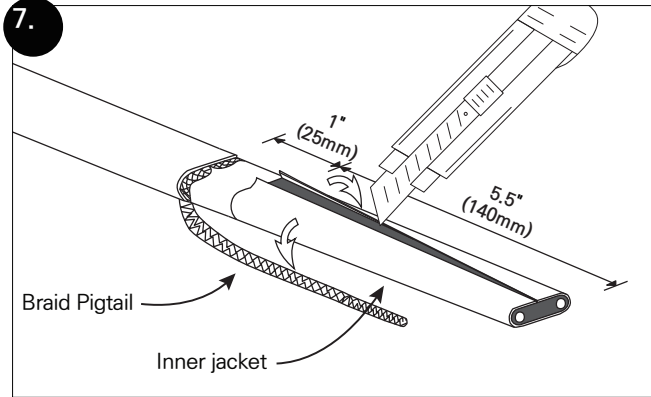

Heating Cable

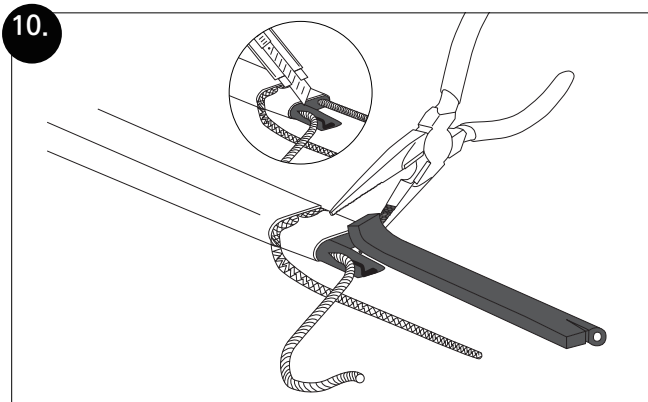
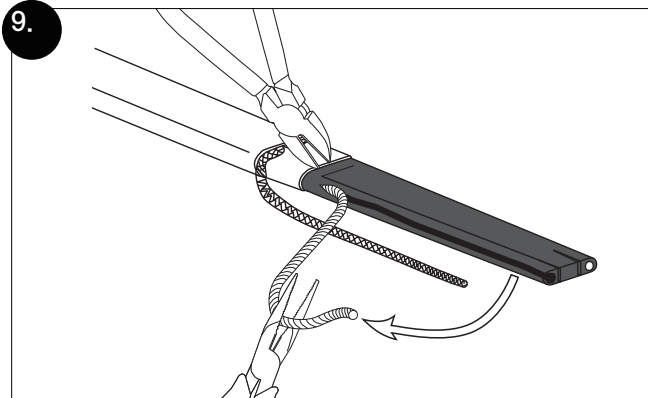

Heating Cable

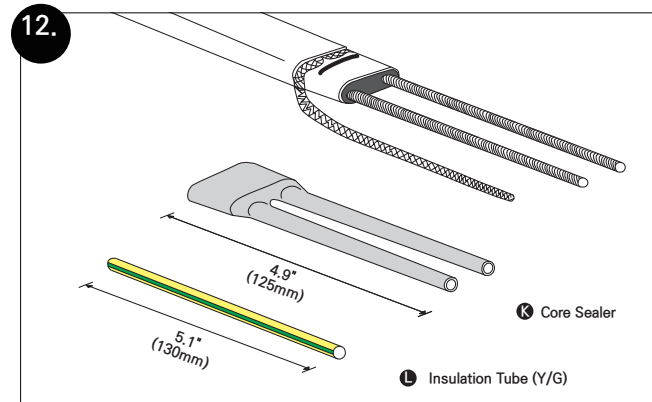
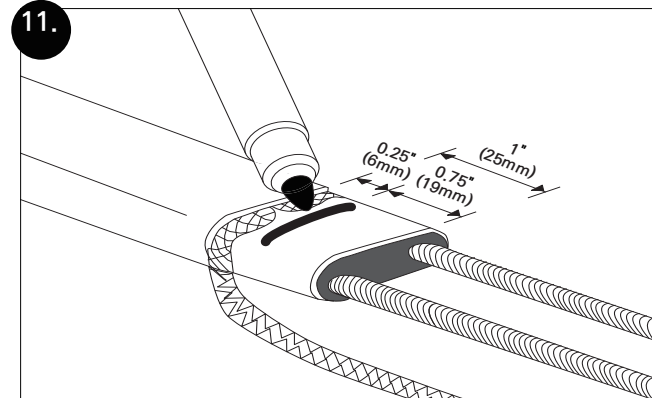

Heating Cable

13.

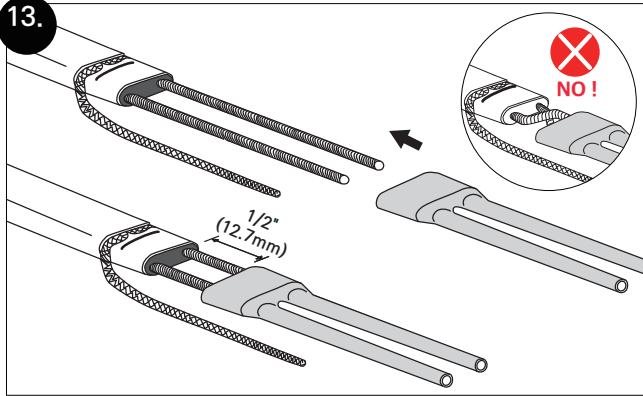

14.

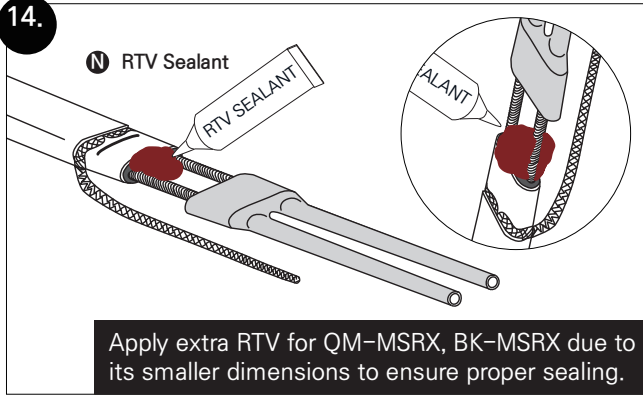

Heating Cable

15.

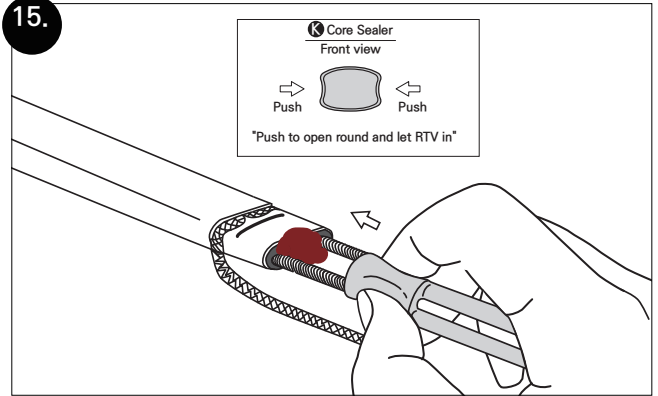

16.

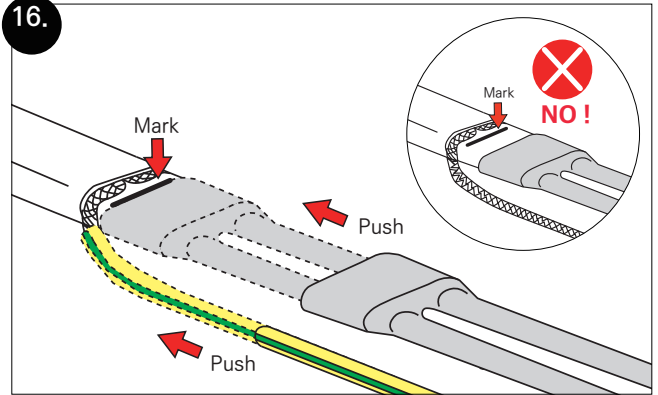

Heating Cable

17.

NOTE : RTV adhesive should ooze out around the core sealer.

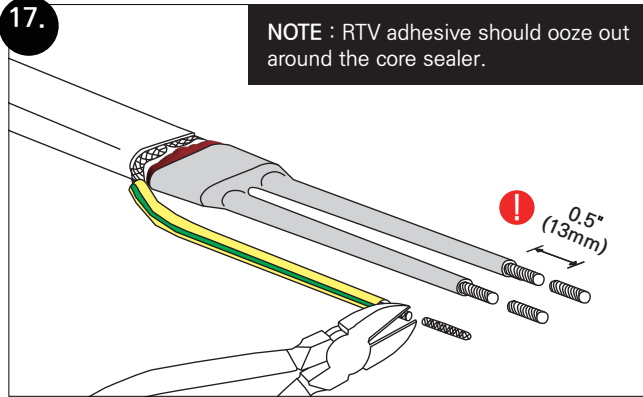

18.

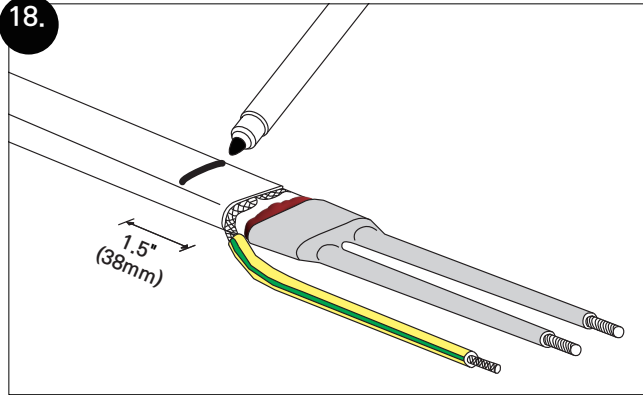

MEP-HT-IPC-1 Kit

19.

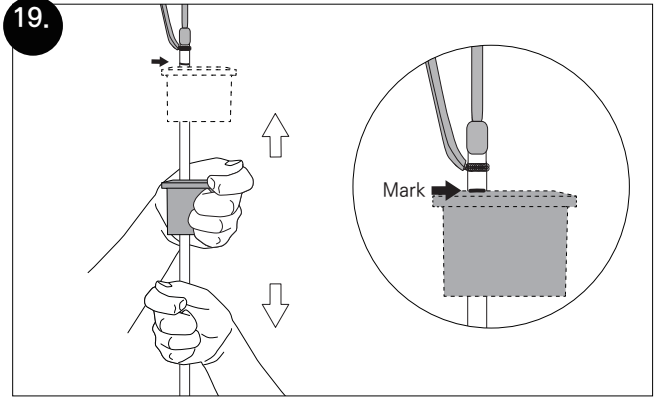

20.

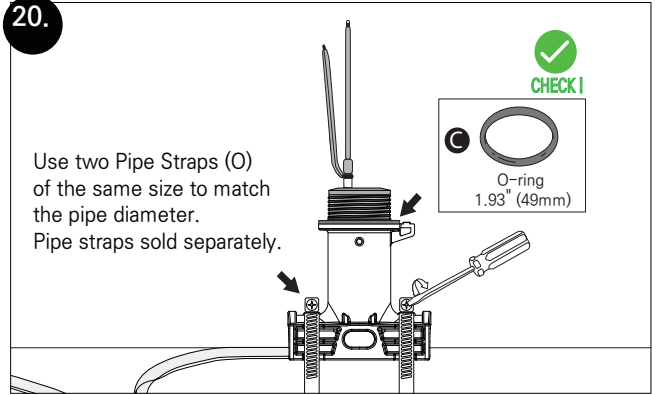

MEP-HT-IPC-1 Kit

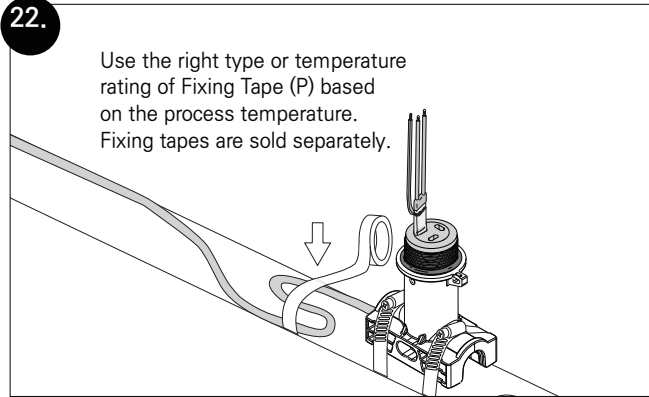
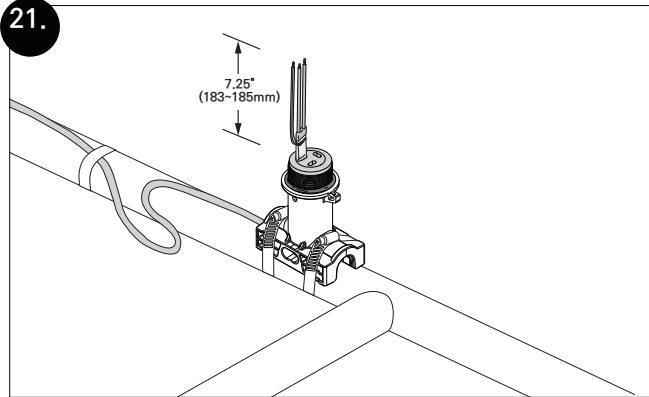

MEP-HT-IPC-1 Kit

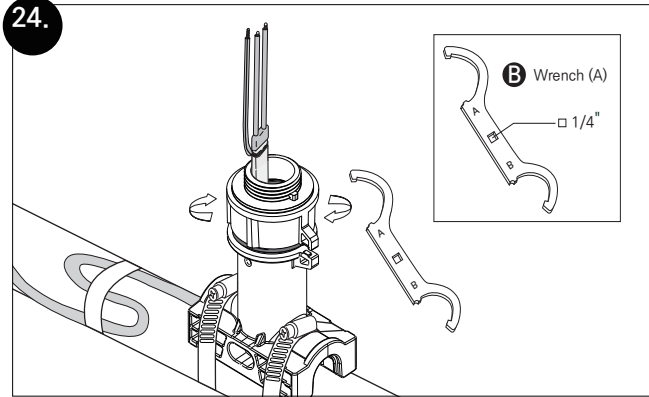
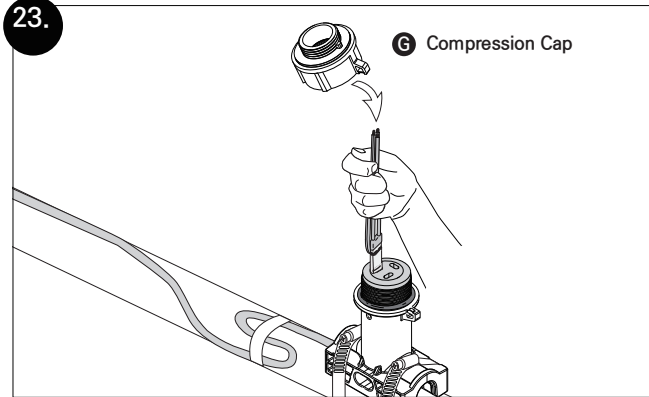

MEP-HT-IPC-1 Kit

25.

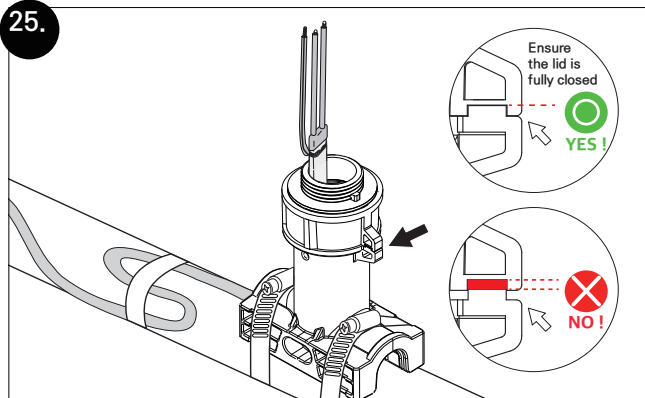

26.

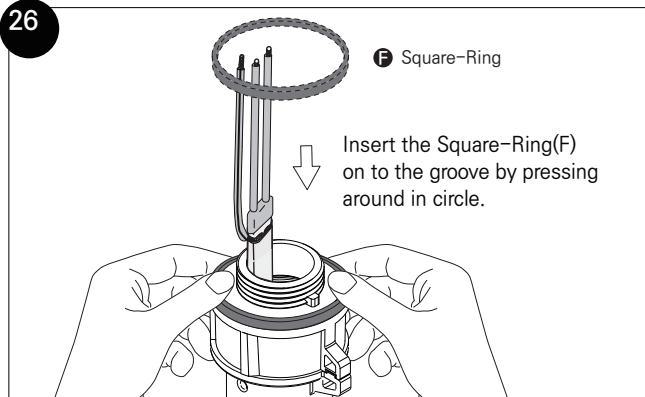

MEP-HT-IPC-1 Kit

27.

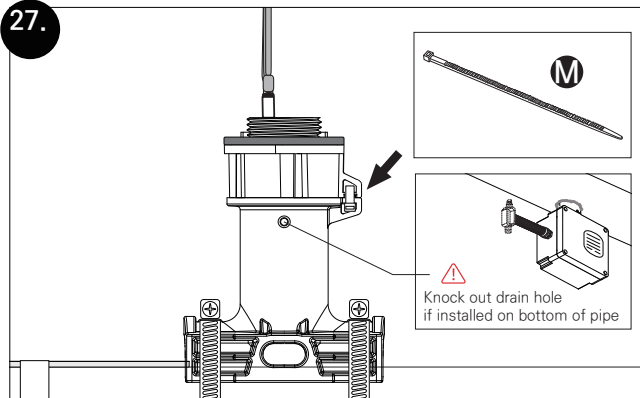

28.

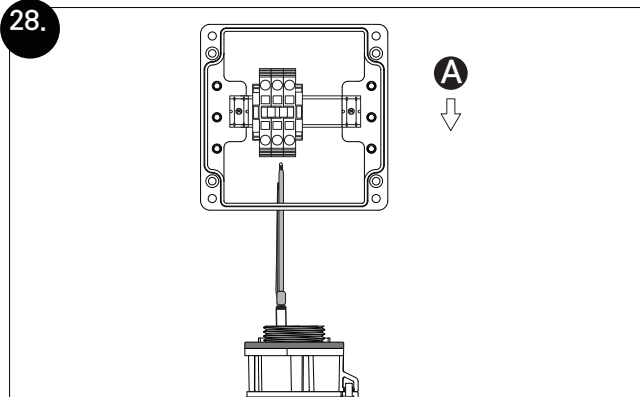

MEP-HT-IPC-1 Kit

29.

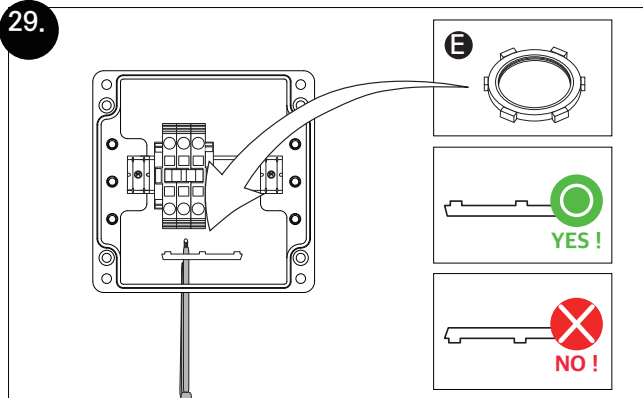

30.

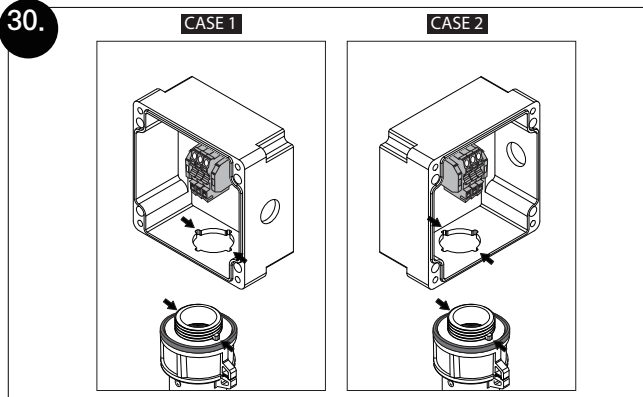

MEP-HT-IPC-1 Kit

31.

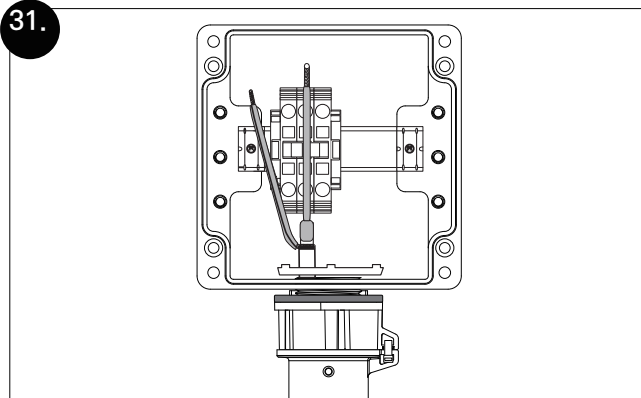

32.

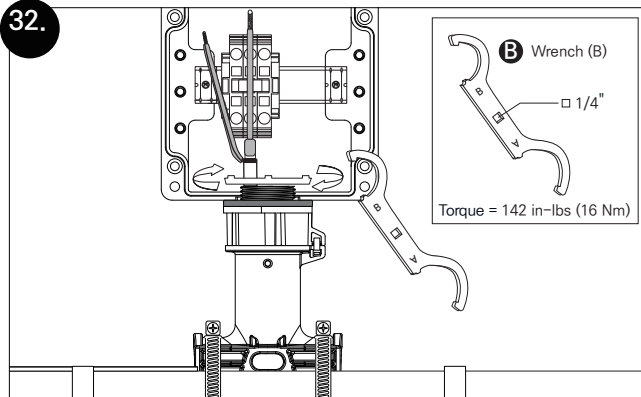

MEP-HT-IPC-1 Kit

33.

Power Connection

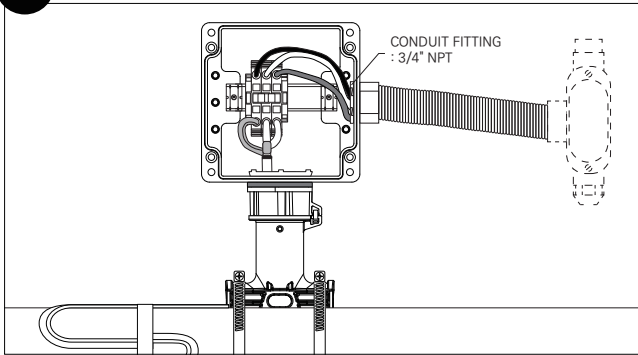

34.

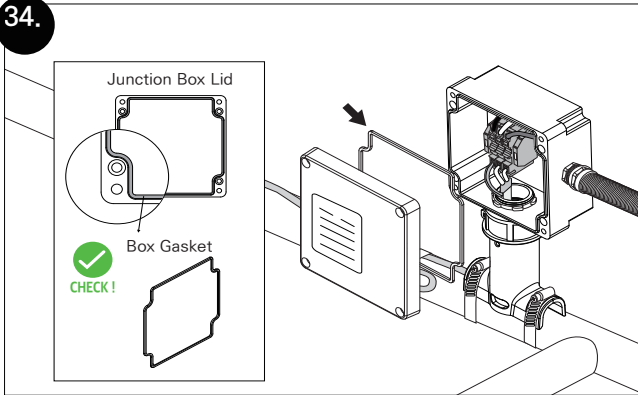

MEP-HT-IPC-1 Kit

35.

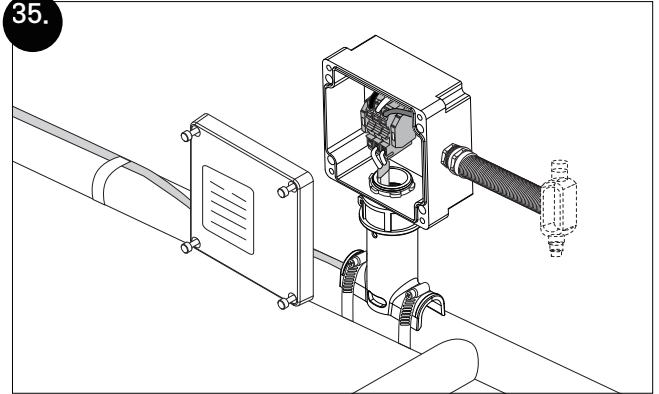

36.

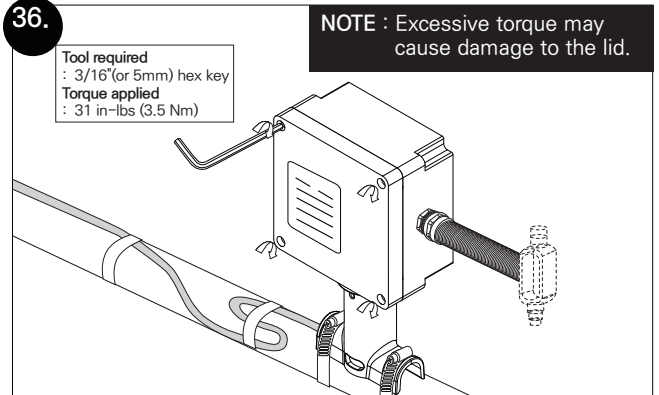

MEP-HT-IPC-1 Kit

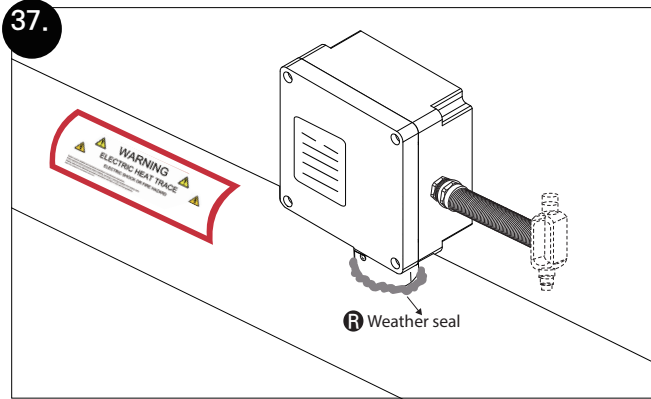

Terminal Blocks

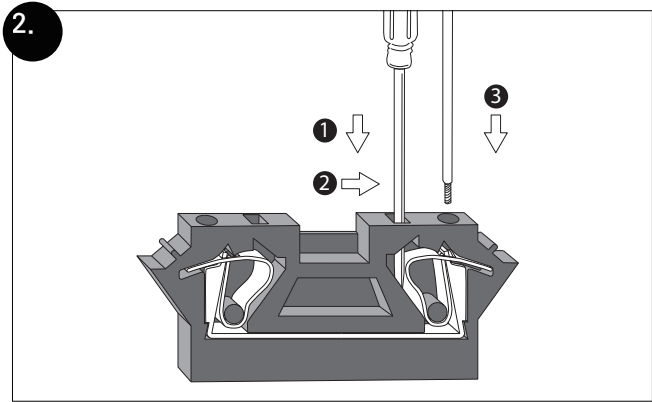
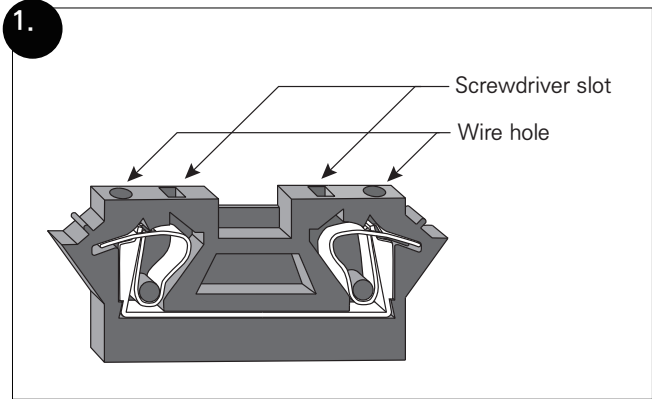

Terminal Blocks

3.

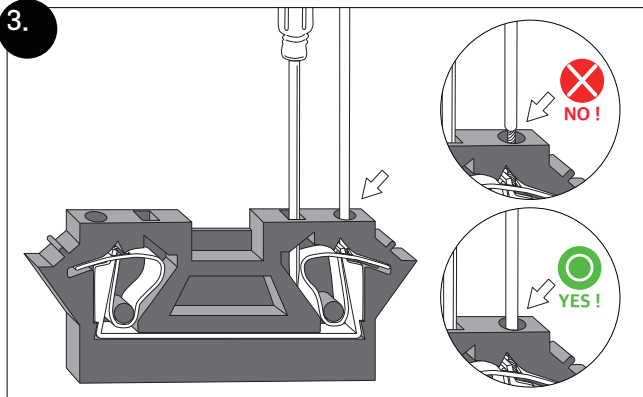

4.

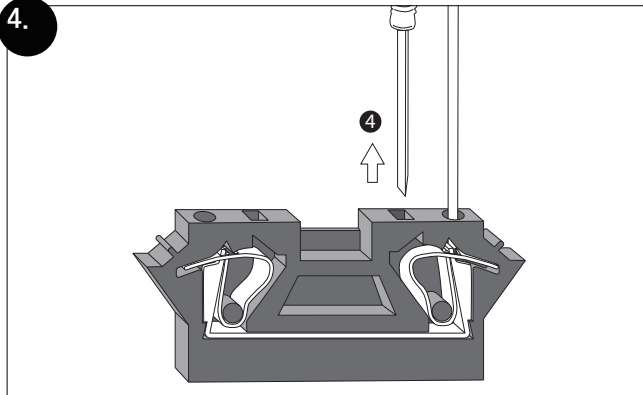

Terminal Blocks

5.

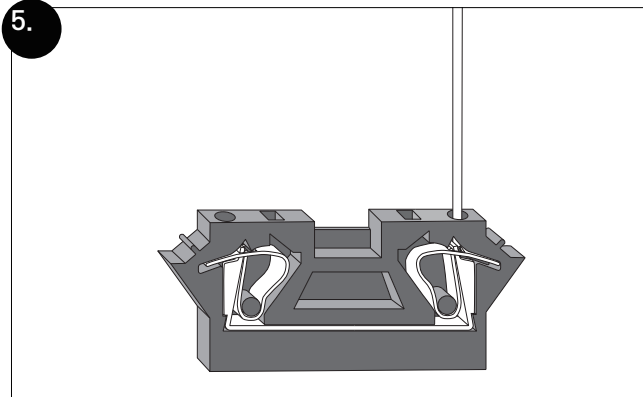

Terminal Blocks Wiring

1. Power Connection

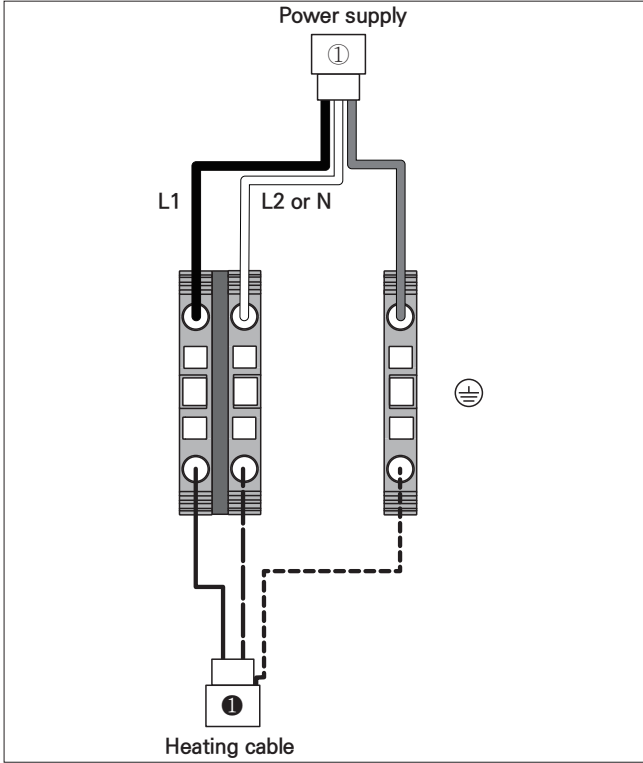

Terminal Blocks Wiring

2. Splice Connection

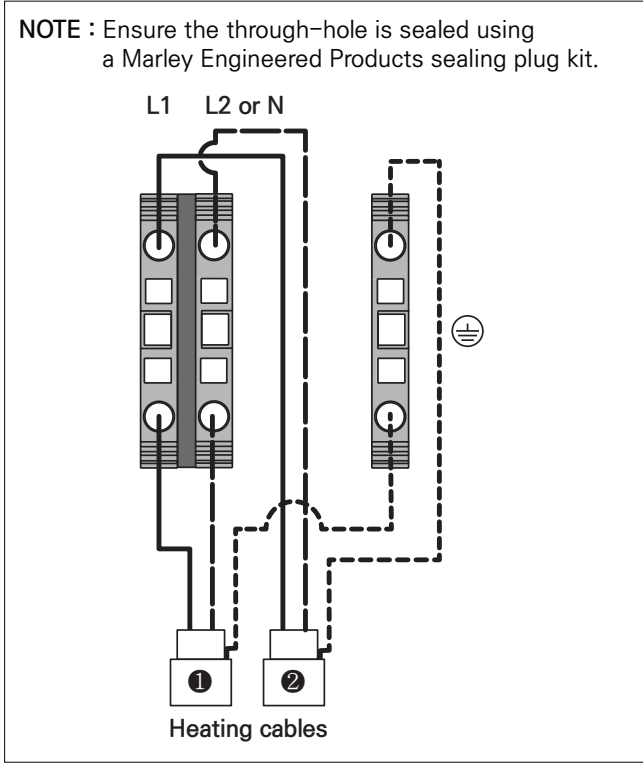

Terminal Blocks Wiring

3.

End Termination

NOTE : Ensure the through-hole is sealed using a Marley Engineered Products sealing plug kit.

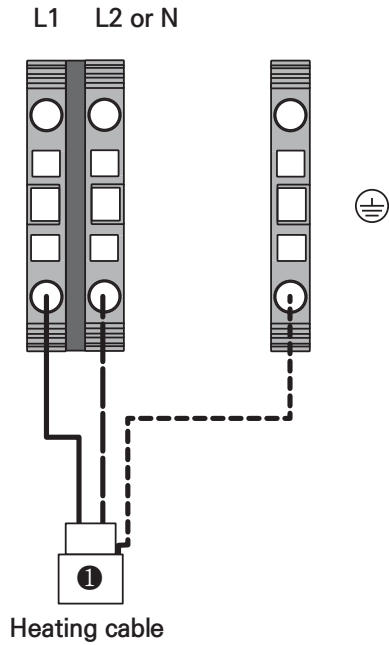



ADDRESS 425 Hanley Industrial Ct, St.Louis, MO 63144

WEB www.marleymep.com