

MEP-HT-IES-1

Installation Instructions

End Seal or In-Line Splice Connection Kit.

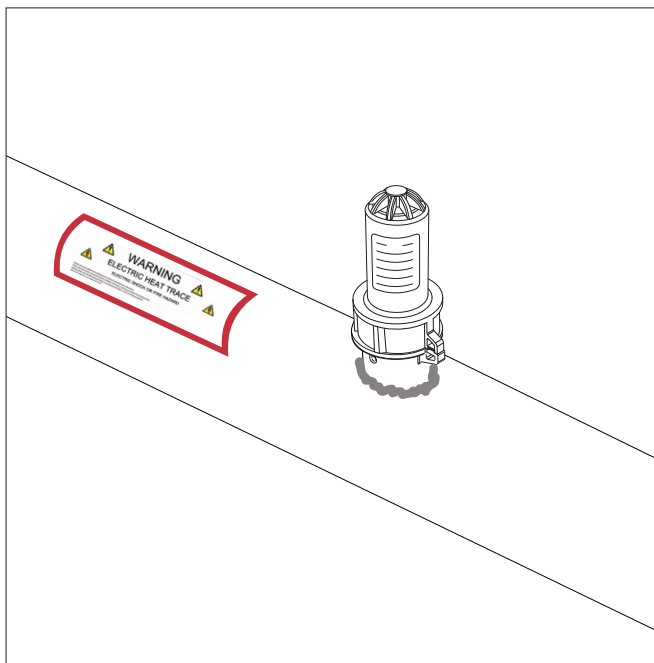

Description

- MEP-HT-IES-1 is an above insulation end seal kit for use with Marley Engineered Products QM-CRGX, BK-CRGX, QM-LSRX, BK-LSRX, QM-MSRX, BK-MSRX and QM-HSRX, BK-HSRX self-regulating heating cables.
- MEP-HT-IES-1 can be used either as an end seal for up to two heating cables or as an in-line splice connection. This kit contains parts for two heating cable end seals.
- For in-line splice connections, the separate “MEP-HT-SK-1” accessory pack is required and sold separately.
- For in-line splice, please go to page 21.

Approvals

MEP-HT-IES-1



FM26US0013X, FM26CA0003X

Hazardous (classified) locations,
indoors and outdoors

Class I, Division 2, Groups A, B, C and D T*;

Class II/III, Division 2, Groups F and G T*;

Class I, Zone 1, AEx/Ex eb IIC T* Gb;

Zone 21, AEx/Ex tb IIIC T* °C Db;

Type 4X, IP66

Ta = -40°C to +55°C

T* = For T-rating, please refer to cable documentation.

Kit Contents

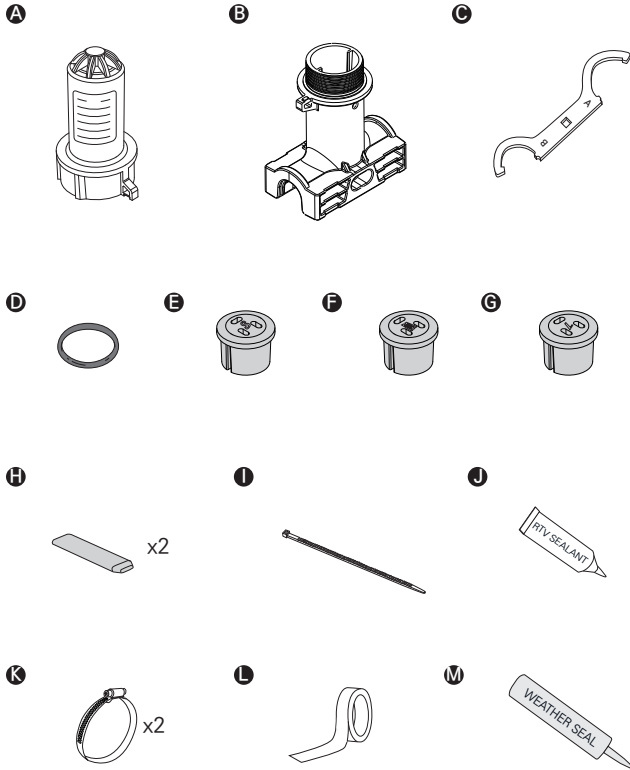

Item	Description	Qty.
A	End Cap	1
B	Pipe Stand	1
C	Wrench	1
D	Stand O-ring	1
E	S Grommet for a*-CRGX-CT, a*-LSRX-CT, a*-MSRX	1
F	M Grommet for a*-CRGX-CR, a*-LSRX-CR	1
G	L Grommet for for a*-HSRX	1
H	Rubber End Cap	2
I	Cable Tie	1
J	RTV Sealant	1
K	Pipe Strap (Sold Separately)	2
L	Fixing Tape (Sold Separately)	1
M	Weather Seal (Sold Separately)	1

· a* = "QM" for QMARK, or "BK" for BERKO

Accessory Package

"MEP-HT-EK-1" for End Seal
(Included in MEP-HT-IES-1 kit)



"MEP-HT-SK-1" for Splice connection
(Sold separately)

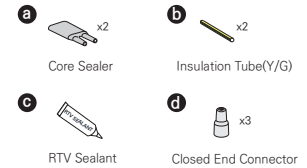

Tools Required

- Wire cutters
- Marking pen
- Adjustable pliers
- Needle nose pliers
- Utility knife
- Large slotted screwdriver
- Molex RHT-7000 crimp tool or equivalent; 10-16AWG slot (For in-line splice connection only)

Additional Materials Required

- Pipe Straps

Model	Pipe Size	Unit Qty.
HTPS-6	Up to 6" Outer Diameter	1 each
HTPS-10	Up to 10" Outer Diameter	1 each

- Small Pipe Adapter

For installation on small pipes (<1" or 25mm diameter), contact Marley Engineered Products for small pipe adapter, model HTSPA-1.

- Fixing Tapes

- HTFT-1 Fiberglass Tape: 3/8" x 66ft. roll
- HTAT-1 Aluminum Tape: 2" x 180ft. roll

CAUTION

- The minimum installation temperature is -40°F (-40°C). For more convenient installation, we recommend performing the installation at a temperature above freezing. Store the kit at a temperature above freezing until installation.

WARNING

- Marley Engineered Products heat-tracing systems must be installed correctly to ensure proper operation and to prevent shocks and fires. Pay attention to warnings and carefully follow applicable installation instructions.
- For two or more heating cables powered by a single circuit, the total length of all heating cables should not exceed the maximum circuit length allowed in the chart published in the Marley Engineered Products self-regulating heating cables datasheets or design guide. Additionally, the total current of all heating cables should not surpass 80% of the circuit breaker rating.
- **Electrical Shock or Fire Hazard** : Follow Marley Engineered Products requirements and comply with NEC, CEC, and all relevant local codes.
Ground-fault equipment protection set at 30 mA must be used on each heating cable branch circuit. Arcing may not be stopped by conventional circuit breakers.
- The approvals and performance of the heat tracing systems are based exclusively on the use of Marley Engineered Products specified parts. It is imperative that parts are not substituted and electrical tape is not used.
- Damaged bus wires have the potential to overheat or cause short circuits. When scoring the jacket or core, it is essential to avoid breaking the bus wire strands.
- Both components and cable ends must be kept dry before and throughout the installation process.
- The potential for bus wires to overheat or short circuit exists

if the bus wire strands are broken while preparing the cable for connection. Reuse of grommets or use of the wrong grommet can result in leaks, cracked components, shocks, or fires. Ensure the type or opening size of grommet is correct for the heating cable being installed. A new grommet is recommended whenever the cable has been pulled out of the component.

- Before and during installation or servicing, all power circuits must be de-energized.
- Read the MSDS for RTV and components carefully.
- Use thermal insulation and attachment tape suitable for the specific application and heat-tracing temperature. Do not secure heating cables with metal straps or wire, as this may damage the cables.

Specific Conditions of Use

- Marley Engineered Products MEP-HT-IES-1 Series Connection Kits must be installed using Marley Engineered Products QM-CRGX, BK-CRGX, QM-LSRX, BK-LSRX, QM-MSRX, BK-MSRX and QM-HSRX, BK-HSRX Series Heating Cables.
- Refer to the installation instructions to reduce the potential of an electrostatic charging hazard on the enclosures of the connection kits.
- The end-user shall mount the equipment per Marley Engineered Products instructions.

End Seal

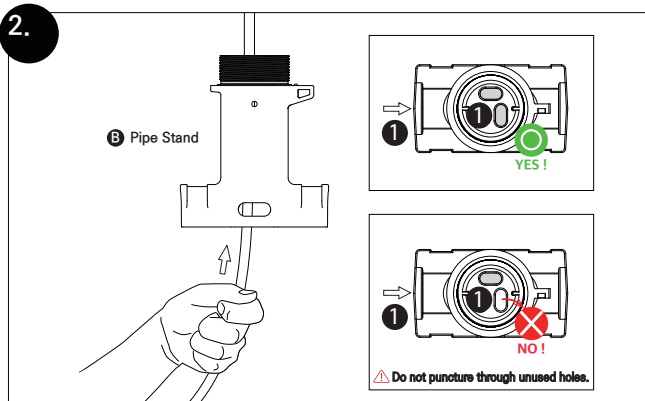
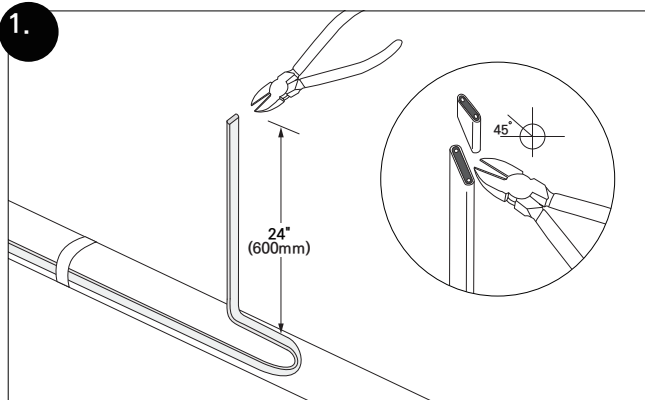

End Seal

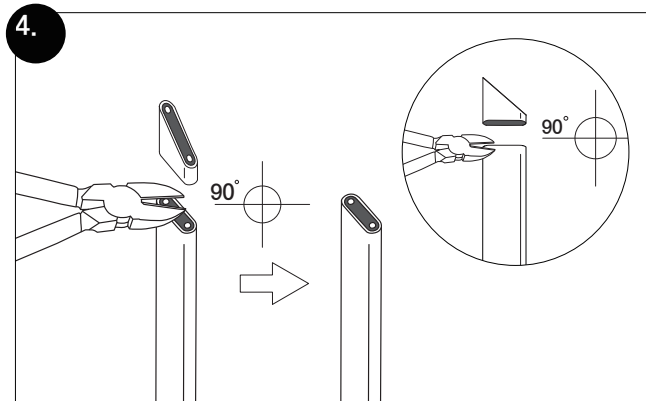
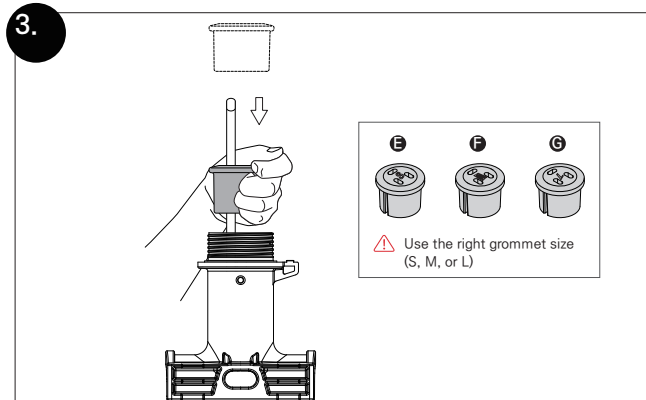

End Seal

5.

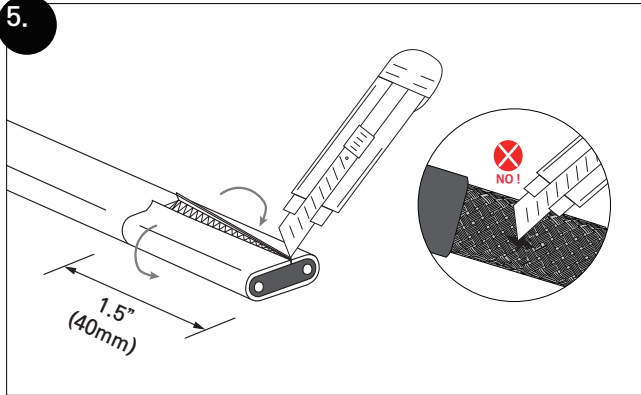

6.

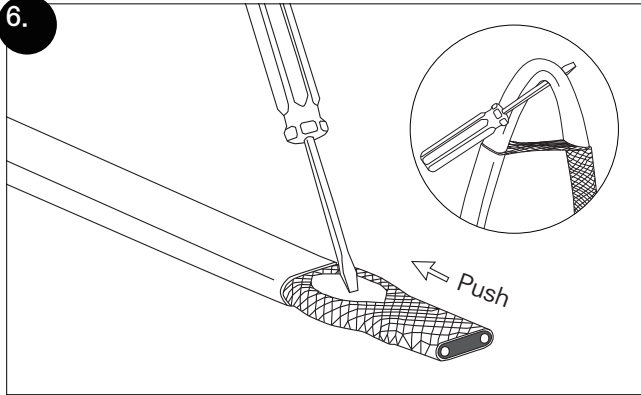

End Seal

7.

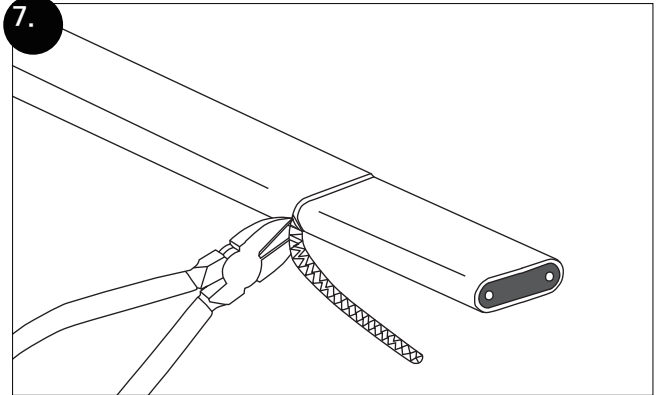

8.

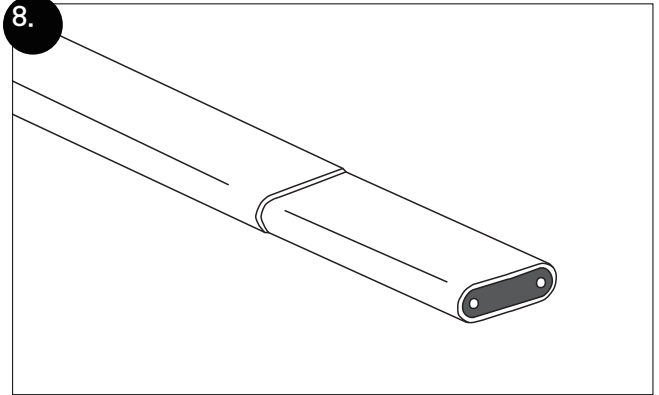

End Seal

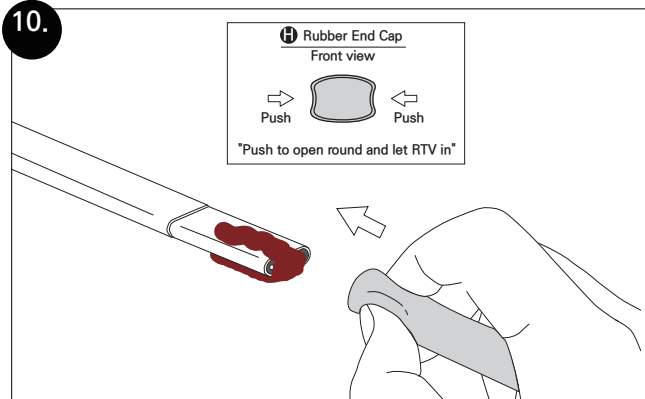
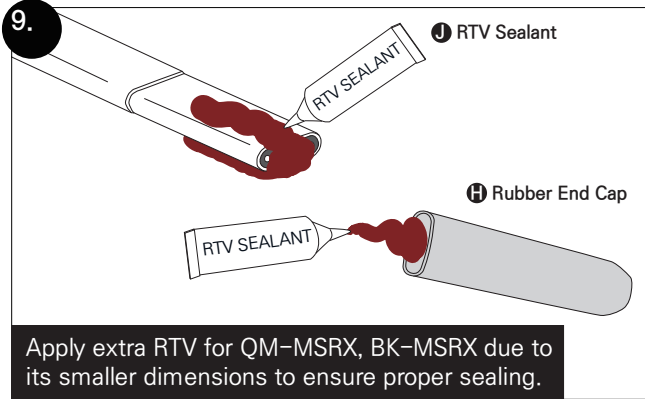

End Seal

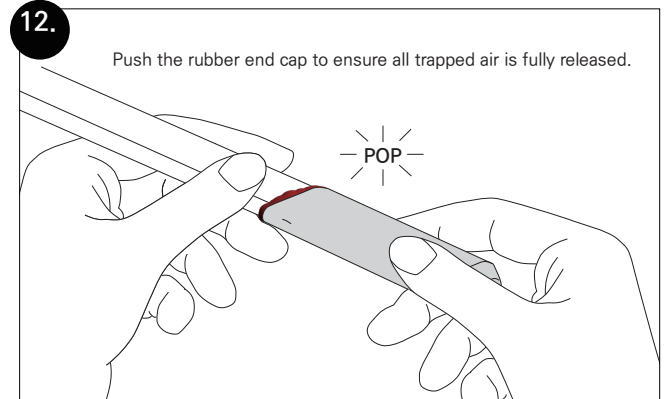
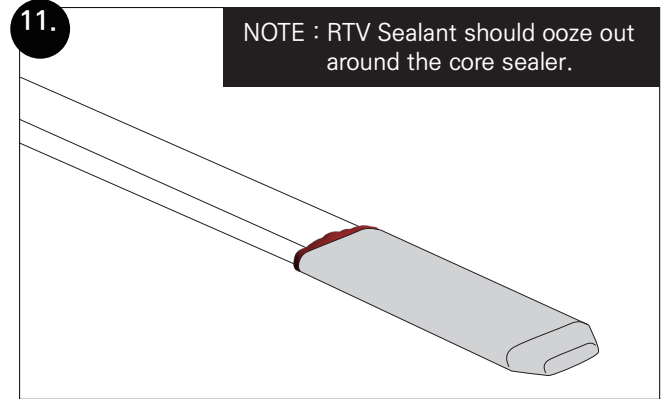

End Seal

13.

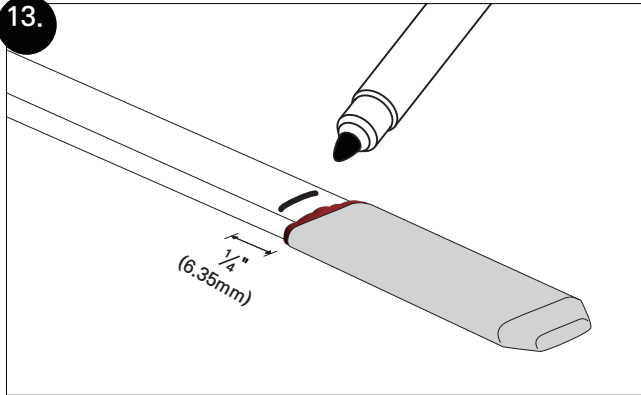

14.

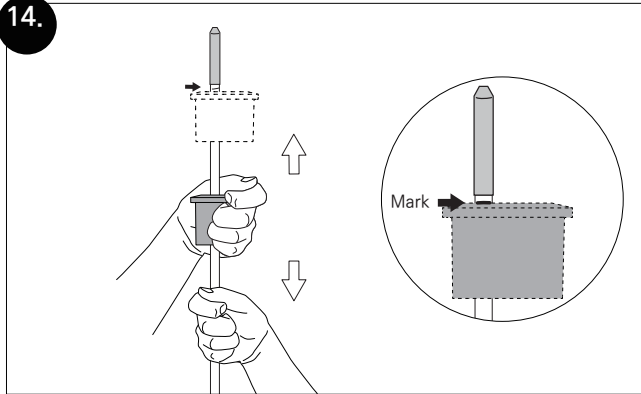

End Seal

15.

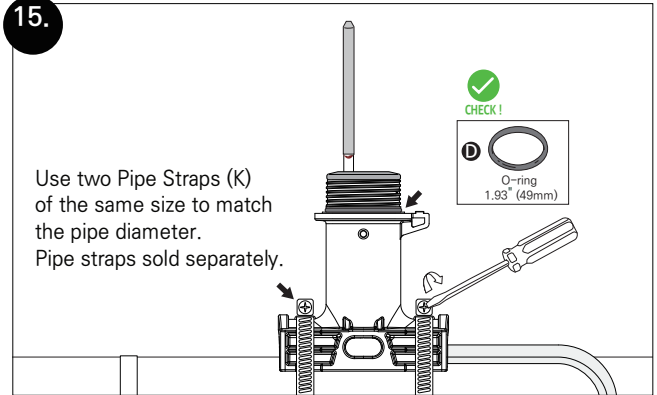

16.

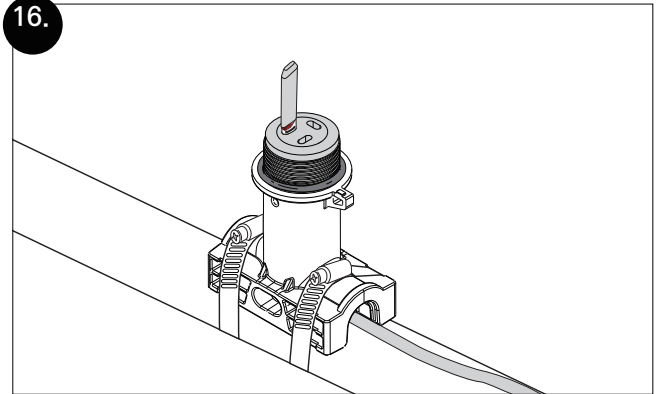

End Seal

17.

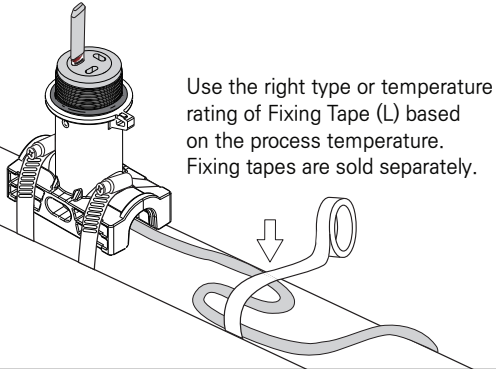

18.

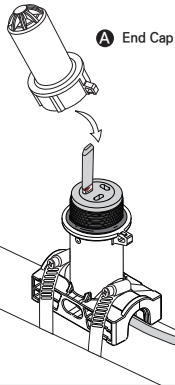

End Seal

19.

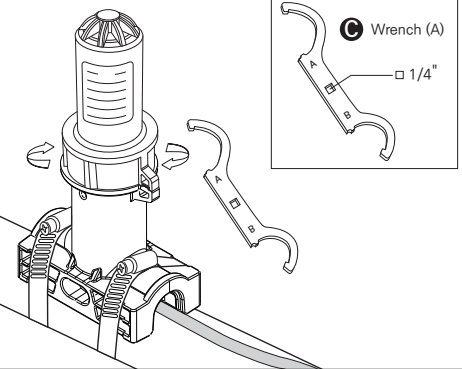

20.

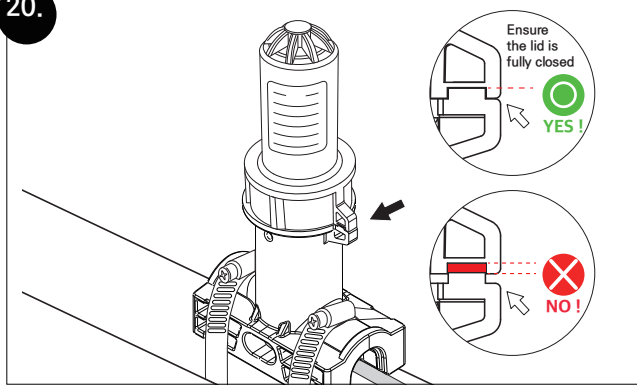

End Seal

21.

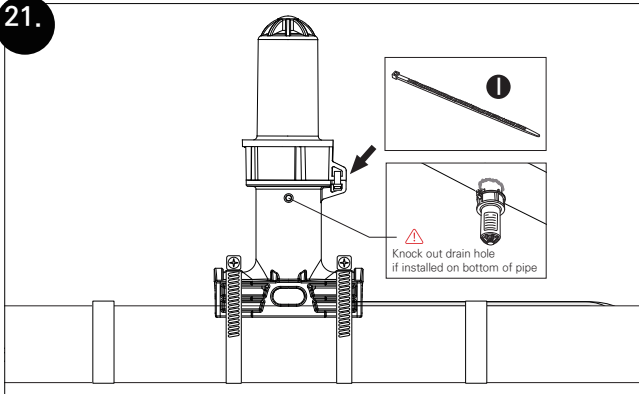

22.

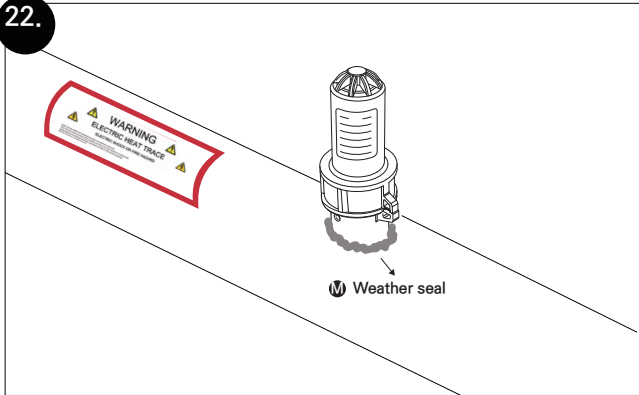

In-Line Splice Connection

Completed picture of splice wiring

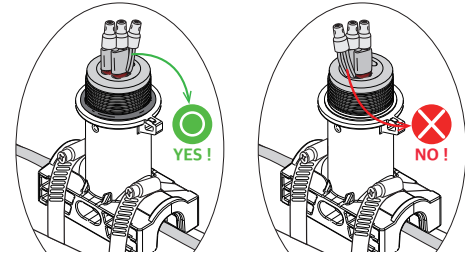

Ensure the braids are pigtailed toward the center of the grommet. If they face outward, the connectors may block the end cap from closing properly.

1.

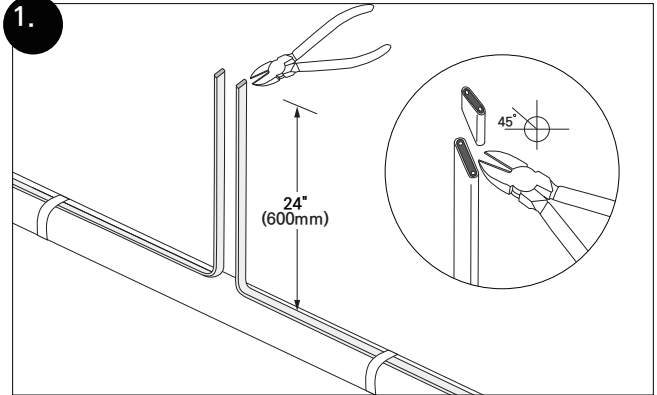

In-Line Splice Connection

2.

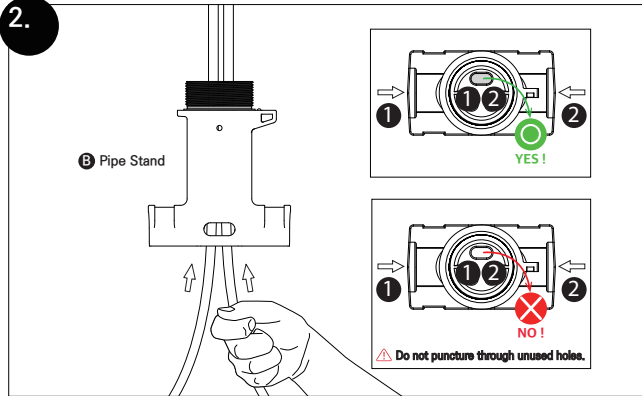

3.

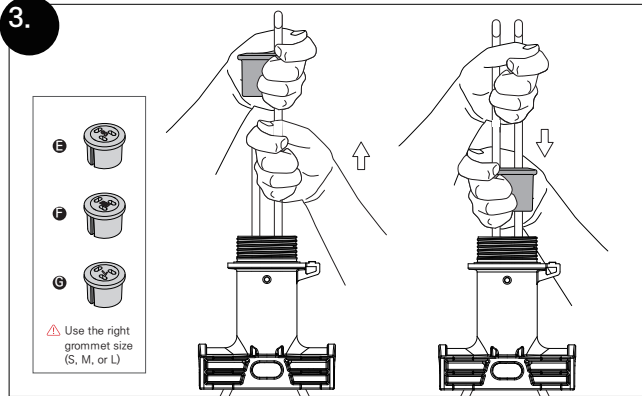

In-Line Splice Connection

4.

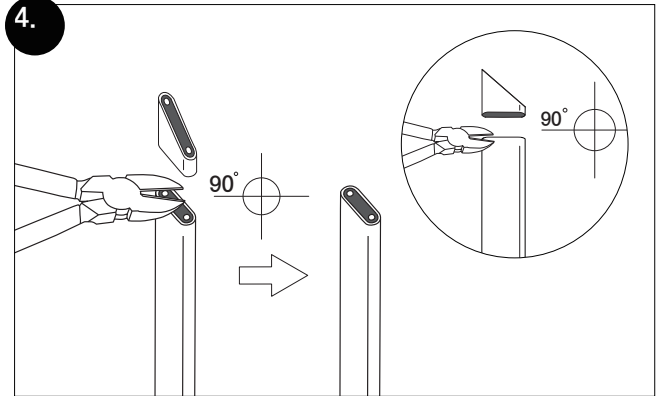

5.

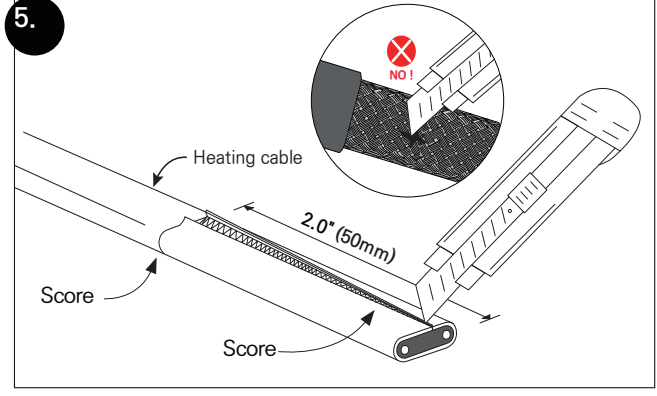

In-Line Splice Connection

6.

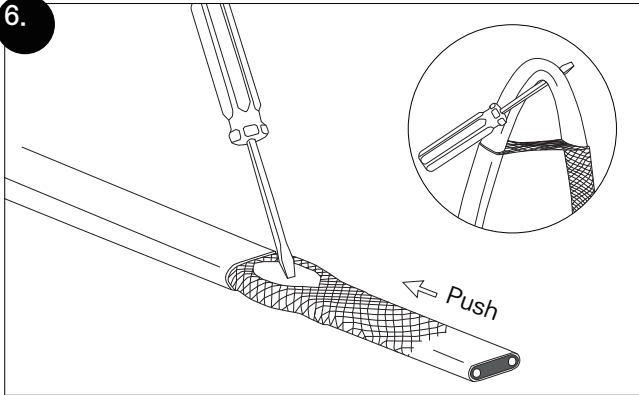

7.

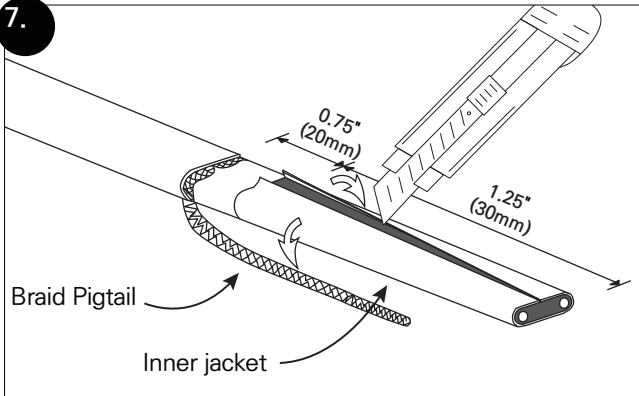

In-Line Splice Connection

8.

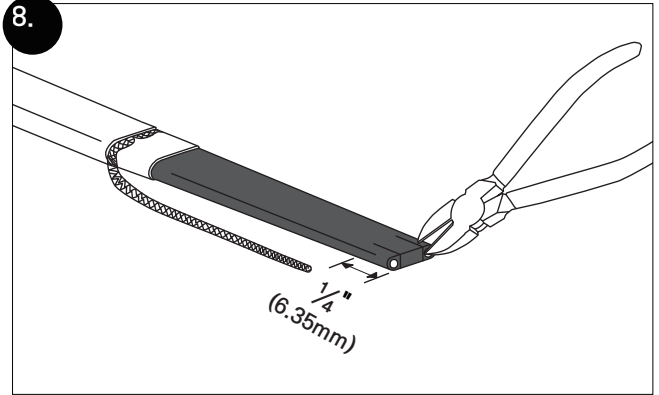

9.

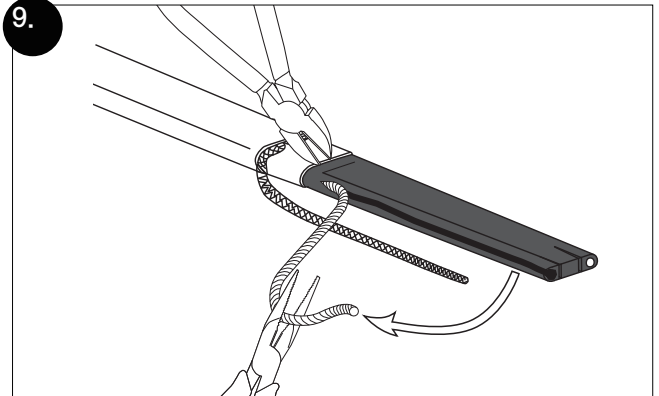

In-Line Splice Connection

10.

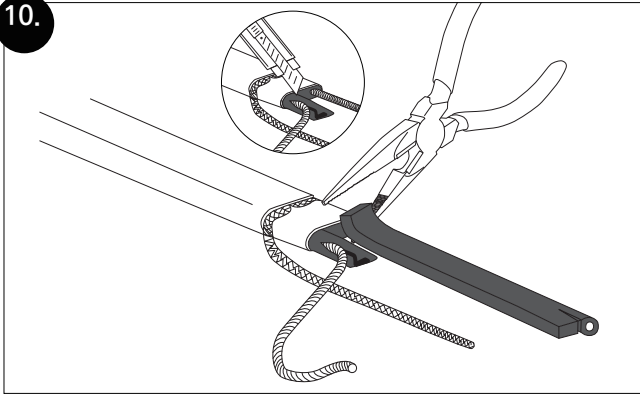

11.

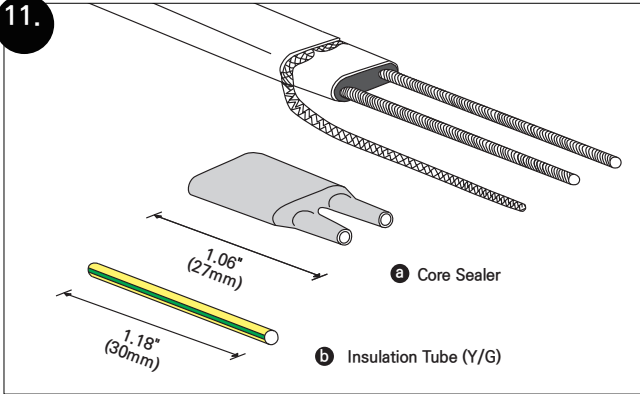

In-Line Splice Connection

12.

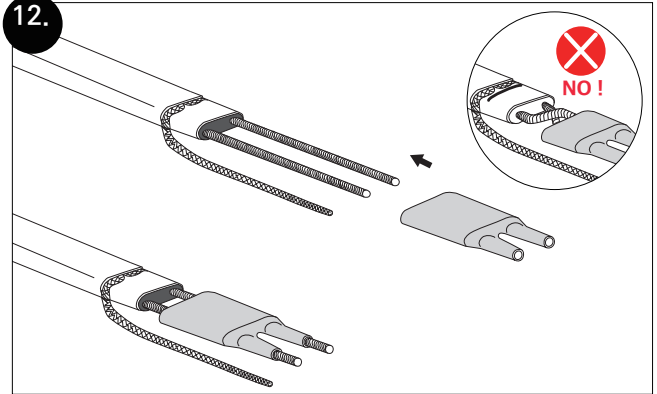

13.

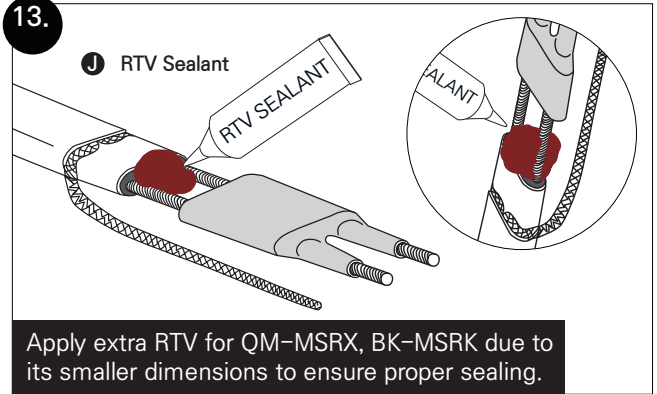

In-Line Splice Connection

14.

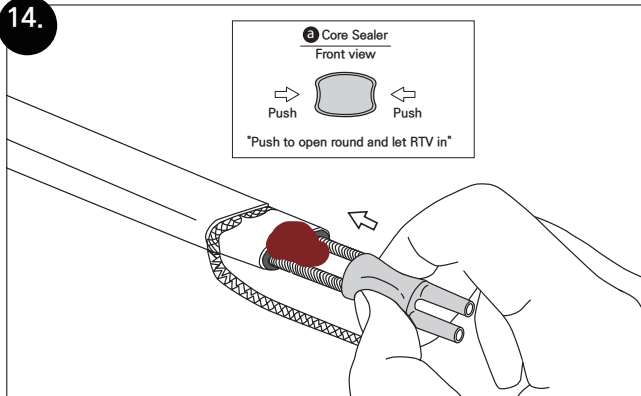

15.

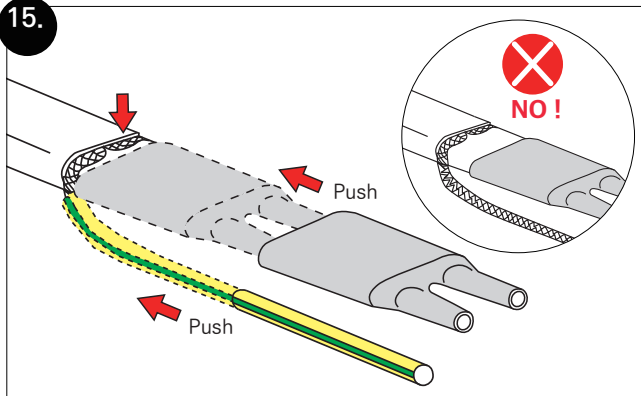

In-Line Splice Connection

16.

NOTE : RTV Sealant should ooze out around the core sealer.

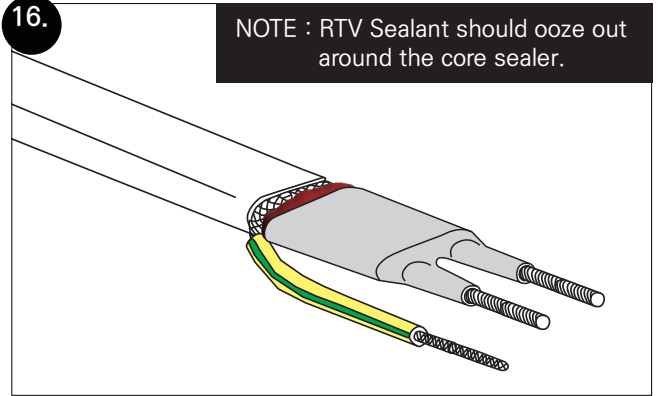

17.

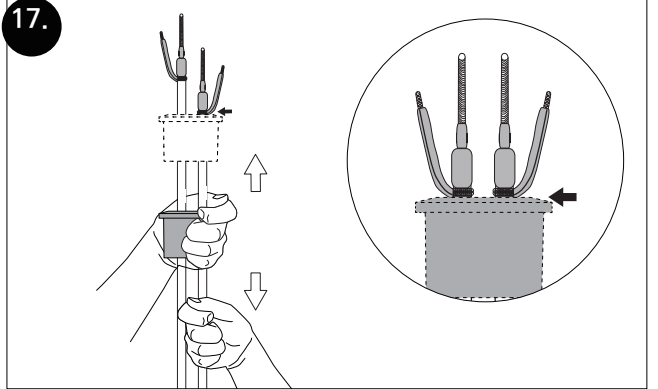

In-Line Splice Connection

18.

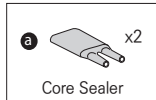

Use two Pipe Straps (K) of the same size to match the pipe diameter. Pipe straps sold separately.

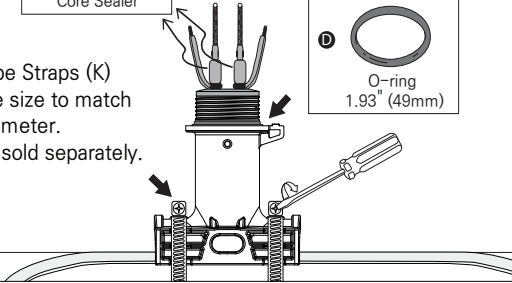

19.

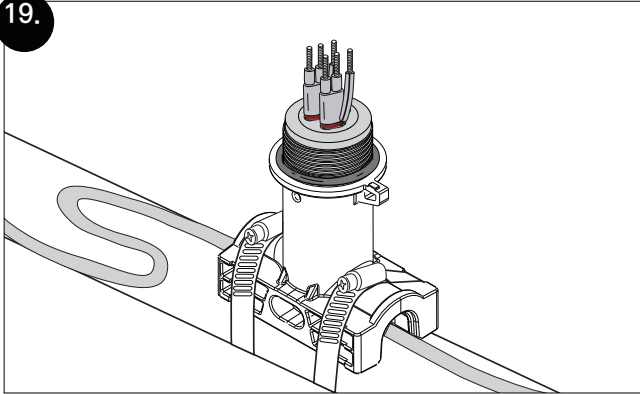

In-Line Splice Connection

20.

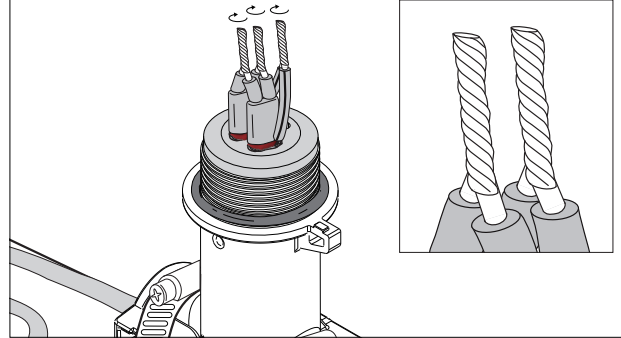

21.

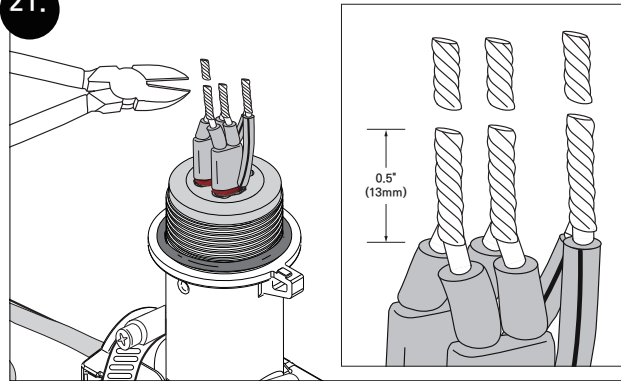

In-Line Splice Connection

22.

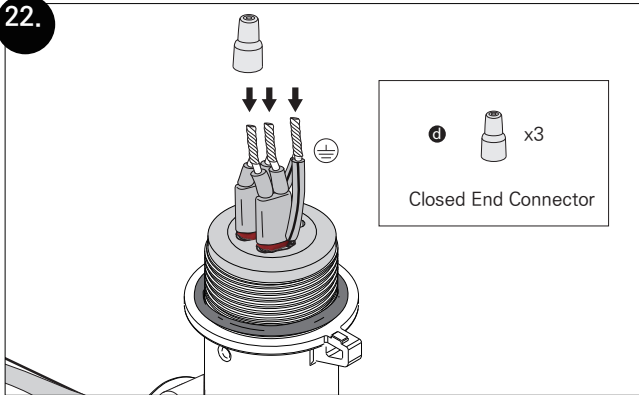

23.

Insert pre-twisted wires
into connector and crimp.

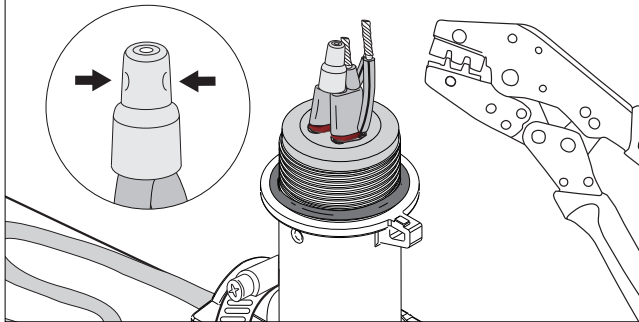

In-Line Splice Connection

24.

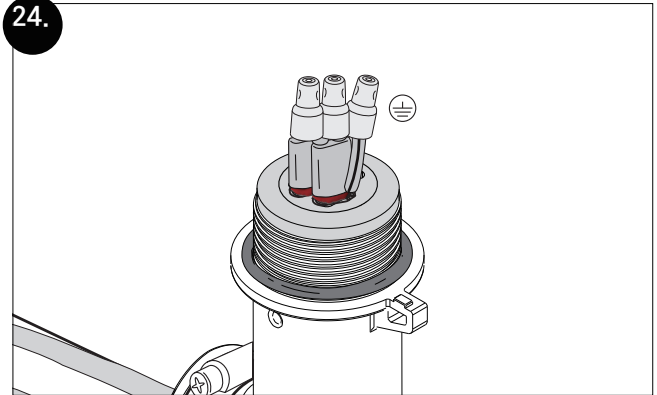

25.

Use the right type or temperature
rating of Fixing Tape (L) based on
the process temperature.
Fixing tapes are sold separately.

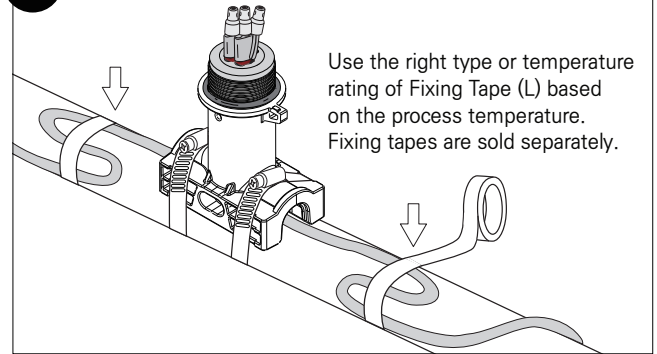

In-Line Splice Connection

26.

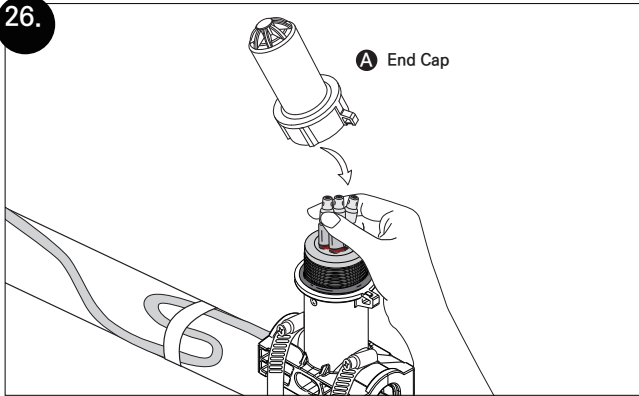

27.

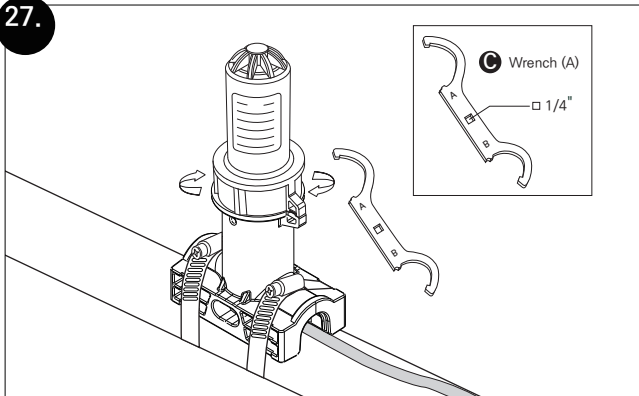

In-Line Splice Connection

28.

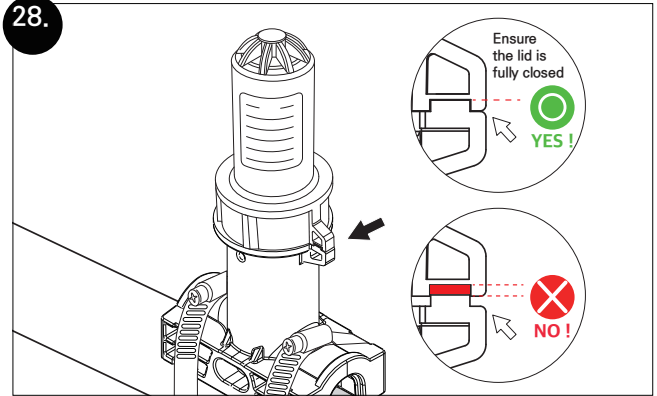

29.

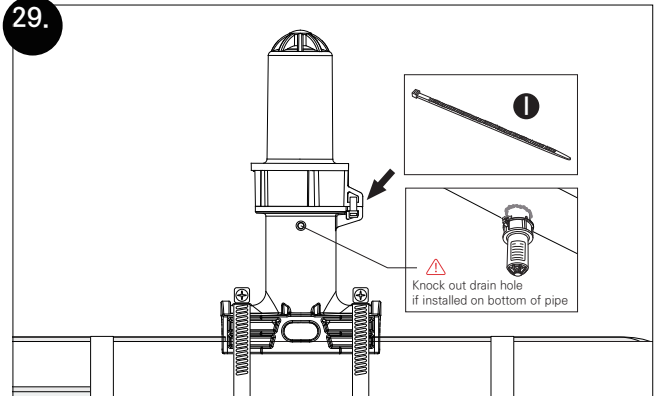

In-Line Splice Connection

30.

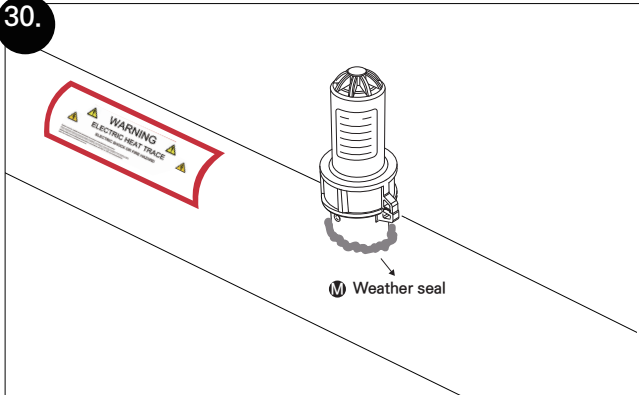



ADDRESS 425 Hanley Industrial Ct, St.Louis, MO 63144

WEB www.marleymep.com