

HUH SERIES

Industrial Unit Heater

UNIT HEATERS



Technical Specifications:

Temp Range: 45°-90°F

CFM: 270-1800

Ideal Spaces:

Factories
Garages
Stockrooms
Stores
Maintenance Rooms
Warehouses
Service Stations
Workshops
Stairwells

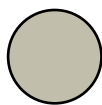

Beige

- › All motors and contactor coils are 240V and operate on the secondary of a factory-installed step-down power transformer on 480V and 600V heaters so a separate fan and motor control power source is not needed
- › Automatic fan delay eliminates cold drafts on start-up and discharges residual heat from the heater body during shut down
- › Steel fins are copper-brazed to low-watt density, steel-sheathed tubular heating elements
- › 5 and 7.5 kW models also come equipped with ceiling mounting bracket for horizontal or vertical flow mounting or any position in between
- › Uniform discharge of all heated air lowers internal operating temperatures and prolongs element life
- › Cabinet is finished with a polyester powder coating for excellent corrosion resistance
- › Element finished with aluminized paint for corrosion resistance
- › Fins and elements are arranged in a uniform grid pattern and fit closely into air discharge area to assure that all incoming air passes through heating element
- › High-limit cut-off automatically shuts off current in the event of overheating and reactivates unit when temperature returns to normal
- › Adjustable louvers provide directional heating to heat desired areas



HUH SERIES

Industrial Unit Heater

Scan the QR code
to access additional
specs and features



Models & Specifications:

ITEM INFORMATION			ELECTRICAL DATA						
CATALOG NO.	UPC	KW	BTU/HR.	VOLTAGE	PHASE	MAX AMPERAGE 3 PHASE	CFM	WEIGHT	
◆ HUH520SA	685360038612	5**	17	208	1-3	12.5	270	26 lbs	
◆ HUH548SA	685360038933	5**	17	480	1-3	6	270	31 lbs	
◆ HUH724SA	685360039121	7.5**	25.6	240	1-3	18.1	270	27 lbs	
◆ HUH748SA	685360039268	7.5**	25.6	480	1-3	9	270	31 lbs	
◆ HUH1020	685360037073	10	34.1	208	1-3	27.8	500	72 lbs	
◆ HUH1024M	685360037134	10	34.1	240	1-3	25.7	500	62 lbs	
◆ HUH1048M	685360037233	10	34.1	480	1-3	12.8	500	72 lbs	
◆ HUH1520M	685360037417	15	51.2	208	1-3	42	750	78 lbs	
◆ HUH1524M	685360037448	15	51.2	240	1-3	37.7	750	68 lbs	
◆ HUH1548M	685360037547	15	51.2	480	1-3	18.8	750	78 lbs	
◆ HUH2048M	685360037769	20	68.2	480	1-3	24.8	1000	78 lbs	
◆ HUH3048L	685360038186	30	102.2	480	3	36.9	1800	142 lbs	
● HUH524SA	685360038711	5**	17	240	1-3	13.8	270	26 lbs	
● HUH2548L	685360038063	25	85.2	480	3	31.1	1300	136 lbs	
● HUH560SA	685360039039	5**	17	600	3	4.8	270	31 lbs	
● HUH760SA	685360039374	7.5**	25.6	600	3	7.2	270	31 lbs	
● HUH1060M	685360037295	10	34.1	600	3	9.6	500	72 lbs	
● HUH1560M	685360037653	15	51.2	600	3	14.5	750	80 lbs	
● HUH2060M	685360037813	20	68.2	600	3	19.3	1000	80 lbs	
● HUH2560L	685360038131	25	85.2	600	3	24	1300	142 lbs	
● HUH3060L	685360038223	30	102.2	600	3	28.9	1800	142 lbs	

SKU Legend: ◆ = Popular Products; ● = Extended Offering (Contact your local Marley Sales Representative for typically associated lead times)

**5 kW and 7.5 kW can be used in horizontal or vertical position. Heaters come equipped with ceiling mounting bracket for horizontal or vertical flow mounting or any position between.

Optional Accessories:

CATALOG NO.	UPC	DESCRIPTION	SHIP WT.
CWB1A	685360018201	Combination wall/ceiling bracket for 5KW thru 15KW units	4 lbs
CWB2A	685360152400	Same as above but for 20KW thru 50KW units	14 lbs
UHTA1	685360152431	Single-Pole Thermostat kit 60-120°F temp. range for field installation in all units	1 lbs
IUHDS30*	685360019956	3-pole power disconnect switch kit for field installation on all horizontal unit heaters rated 24 amps or less.	1 lbs
IUHDS63*	685360019963	3-pole power disconnect switch kit for field installation on all horizontal unit heaters 10KW and above rated 24 to 50 amps.	1 lbs
IUHSW	685360036724	Summer-Winter Fan Switch Kit. Field installed. Provides summer fan operation.	1 lbs

Dimensions and Clearances:

KW Size	A	B	C	D	E	F	G	H	I	J
5-7.5	14"	12 1/2"	12 3/8"	5 1/2"	13"	1 3/4"	1 3/8"	1 1/2"	(2) 1/2", 3/4"	1/2"
10-20	18"	18"	17 1/2"	9 15/32"	*	2"	2 1/2"	2 1/4"	(2) 3/4", 1"	(3) 1", 1 1/4", 1 1/2"
25-30	26"	24"	23 1/8"	9 15/32"	20"	2"	2 3/4"	2 1/4"	(2) 1", 1 1/2"	(3) 1", 1 1/2", 2"

*13 in. for 10-15 kW units; 16 in. for 20 kW unit. 5 kW and 7.5 kW can be used in horizontal or vertical position. Heaters come equipped with ceiling mounting bracket for horizontal or vertical flow mounting or any position between.

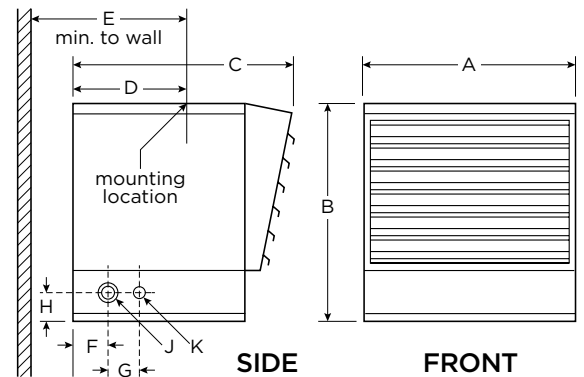

Limited space? We've got your customized comfort covered.

Choose the HUH Series Horizontal/Downflow Unit Heater for basic heating or the HUHTA/ST Bundle with an included mounting bracket and built-in thermostat for one-stop-shopping. Both have adjustable louvers and flexible mounting options that enable you to take aim at the cold. Best of all, both heaters will keep your coldest spots warm and comfortable for years to come.