

## HUHAA PRO SERIES UNIT HEATER



### IDEAL SPACES

- Factories
- Warehouses
- Garages
- Stairwells
- Shipping Docks
- Power Stations
- Mechanical Rooms

### COLORS

- Statuary Bronze

### DIMENSIONS

- Varies (see diagram)

### TEMP RANGE

- 40°– 90°F

### CFM

- 350 – 650



Now compatible  
with SmartSeries  
Plus when used  
with 24VAC control  
transformer!



Introducing the HUHAA PRO series Unit Heaters. Same great HUHAA you rely on everyday but now with added safety and control. The new HUHAA Pro series comes standard with:

- A disconnect switch to make maintenance a safe and easy process.
- A 24VAC transformer for safer control as well as future proofing in case a low voltage digital thermostat is desired in the future.
- A built in single stage thermostat which gives basic control right out of the box.
- PRO-SSP Models come with the SmartSeries Plus ready to be remote mounted, to give you BMS communication via BACnet MS/TP, digital touchscreen, 7 day schedule, temporary override or setback, and cooling mode to run only the fan.

Benefits of the HUHAA PRO:

- **Safety:** The integrated disconnect switch and low voltage transformer add additional safety to the base HUHAA lineup. The disconnect switch gives peace of mind to the maintenance worker because the disconnect switch will cutoff incoming power to the unit so it can be easily repaired. The low voltage transformer no longer requires you to work with line voltage control for easy and safer control.
- **Better Lead Times:** The HUHAA PRO series heater will be a stock product so they will have the same lead times as the base HUHAA models we have today meaning no long wait for configured units!
- **Better Pricing:** Enjoy the benefits of the three added accessories without the full cost of a similar configured style unit.
- **Easy Setup:** All of the accessories are installed in the factory so once the product reaches your door it just needs to be wired then set via the built in thermostat and you are good to go.
- **Easily Stocked:** With all the features and product built as a stock it is easy to keep on the shelves of distributors so you can get the product right when you need it.

[www.berkomep.com](http://www.berkomep.com)

For Technical Services, Call 800-642-4328

ITEM# BFLY\_HUHAA\_0321-2

**BERKO**<sup>®</sup>  
A Marley Engineered Products Brand

## HUHAA PRO SERIES UNIT HEATER

Item Information		Electrical Data					Fan Data	Mechanical Data
Catalog No.	UPC	VOLTS	PHASE	KW	AMPS	Control Volt	CFM	Ship WT.
HUHAA320-PRO	00685360174297	208	1	3	14.5	24	350	27 lbs
HUHAA320-PRO-SSP	00685360174747	208	1	3	14.5	24	350	27 lbs
HUHAA520-PRO	00685360173993	208	1-3	5	24	24	350	27 lbs
HUHAA520-PRO-SSP	00685360174792	208	1-3	5	24	24	350	27 lbs
HUHAA720-PRO	00685360174020	208	1-3	7.5	36	24	650	38 lbs
HUHAA720-PRO-SSP	00685360174808	208	1-3	7.5	36	24	650	38 lbs
HUHAA1020-PRO	00685360173931	208	1-3	10	48	24	650	38 lbs
HUHAA1020-PRO-SSP	00685360174594	208	1-3	10	48	24	650	38 lbs
HUHAA324-PRO	00685360173979	208/240	1	3	11.0/12.5	24	350	27 lbs
HUHAA324-PRO-SSP	00685360174754	208/240	1	3	11.0/12.5	24	350	27 lbs
HUHAA524-PRO	00685360174006	208/240	1-3	5	18.0/21.0	24	350	27 lbs
HUHAA524-PRO-SSP	00685360174785	208/240	1-3	5	18.0/21.0	24	350	27 lbs
HUHAA724-PRO	00685360174037	208/240	1-3	7.5	27.0/31.3	24	650	38 lbs
HUHAA724-PRO-SSP	00685360174815	208/240	1-3	7.5	27.0/31.3	24	650	38 lbs
HUHAA1024-PRO	00685360173955	208/240	1-3	10	36.0/42.0	24	650	38 lbs
HUHAA1024-PRO-SSP	00685360174723	208/240	1-3	10	36.0/42.0	24	650	38 lbs
HUHAA348-PRO	00685360173986	480	3	3	3.6	24	350	27 lbs
HUHAA348-PRO-SSP	00685360174761	480	3	3	3.6	24	350	27 lbs
HUHAA548-PRO	00685360174013	480	3	5	6	24	350	27 lbs
HUHAA548-PRO-SSP	00685360174778	480	3	5	6	24	350	27 lbs
HUHAA748-PRO	00685360174044	480	3	7.5	9	24	650	38 lbs
HUHAA748-PRO-SSP	00685360174822	480	3	7.5	9	24	650	38 lbs
HUHAA1048-PRO	00685360173948	480	3	10	12	24	650	38 lbs
HUHAA1048-PRO-SSP	00685360174730	480	3	10	12	24	650	38 lbs

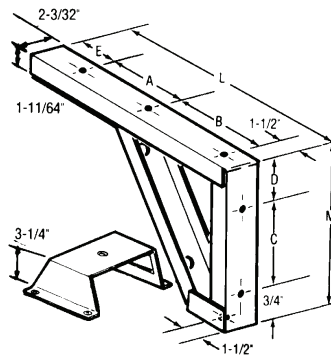
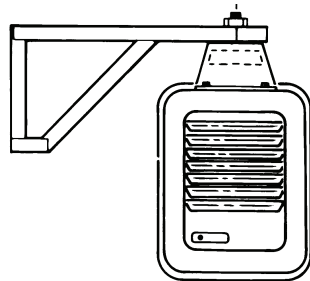

### Optional Mounting Brackets:

	CATALOG NO.	UPC	COMPATIBILITY	SHIP WT.
<b>Standard</b>	B10	685360152295	MUH03-10	8 lbs
<b>Ceiling</b>	CMB10	685360152363	MUH03-10	3 lbs
<b>Vertical Ceiling</b>	VDMB5	685360152455	MUH03-05	5 lbs

	3-20 kW	25-50 kW
A	7 1/4"	9 7/16"
B	9 1/2"	14 3/8"
C	7 1/4"	12 1/8"
D	11 5/16"	2 1/16"
E	2 1/4"	3"
L	20 1/2"	28 15/16"
M	9 15/16"	14 15/16"
N	3 1/4"	4 1/2"

NOTE: On dual-voltage units CFM, FPM, & RPM ratings are listed at higher voltage operation. On dual-phase units maximum amp draw is listed for respective voltage.

## SMARTSERIES® PLUS



The new SmartSeries Plus is the first digital touchscreen control capable of running a fully programmable internal schedule as well as having the capability to connect to a BACnet Building Management System.

### IDEAL SPACES

- Offices/Conference Rooms
- School Hallways
- Churches
- Transportation Terminals
- Stairwells
- Entrance Ways
- Vestibules
- Lobbies
- Mechanical Rooms

### COLOR

- White

### DIMENSIONS

- 6-1/32"W x 4-58"H

### TEMP RANGE

- 50°– 100°F

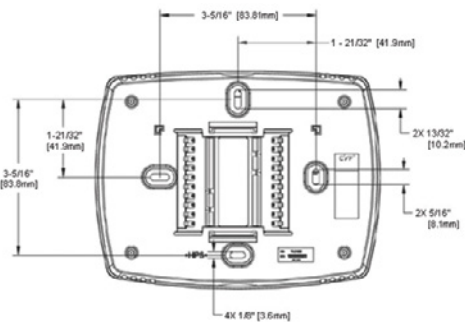

### Intelligent Controls for Intelligent Buildings

- This control comes ready to connect to your Building Management System using BACnet MS/TP protocol. With just a few button presses on the digital touchscreen and simple 2 wire connection, you will have full control over your electric heater in no time!

### Reduced Operations & Maintenance Time

- Use of BMS saves facility manager time and personnel cost by eliminating the need to travel to the heater site and inspect and diagnose root cause.
- Contains 2 scheduling modes: Setpoint Mode (Heating Mode) and Dual Setpoint Mode (Heating & Cooling, Fan Only). Run the heater only when directed by the internal schedule of the BMS!

### Control at your Fingertips

- No BMS? No Problem! You can still get heat when and where you need it by using the built in 7 day programmable scheduling feature.
- Occupancy Settings: Quickly Schedule multiple periods per day, at your desired temperature, for operation based on when you expect occupants to use your space. Comes with 'Copy' function for quick settings of known repeat occupancy periods.

### Other Features

- Lockable Key Pad – Protects the unit from unauthorized access and/or tampering giving you peace of mind the heater is running the way you want it to.
- Temperature Override – Control your comfort even further by allowing users to set a temperature above programmed setpoints for up to 4 hours in an unoccupied state.

