

# TECHNICAL GUIDE

## COMMERCIAL INDUSTRIAL & SPECIAL APPLICATION CEILING FANS



*DOCUMENTED BY:*

**LEADING EDGE**<sup>®</sup>  
A Marley Engineered Products Brand

# THE INTELLIGENT APPROACH TO COMMERCIAL / INDUSTRIAL CEILING FANS

## TABLE OF CONTENTS

INTRODUCTION TO CEILING FANS .....	3-4
CEILING FAN AIR PATTERNS .....	5
HOW CEILING FANS WORK .....	6
BLADE AND MOTOR DESIGNS .....	7-8
CAPITOL COST COMPARISON .....	9
FAN PLACEMENT COMPARISON .....	10
TRUTH IN TESTING .....	11
ESTIMATED ANNUAL SAVINGS FOR HEAT RECOVERY .....	12-14
LEADING EDGE MOTOR CONSTRUCTION .....	15-16
COMMERCIAL/SPECIAL APPLICATION FAN DATA .....	17-20
INDUSTRIAL APPLICATION FAN DATA .....	21-23
REVERSING CEILING FANS .....	24
HARSH ENVIRONMENT CEILING FANS .....	25
FAN PLACEMENT CALCULATIONS .....	26
ADJUSTABLE MOTOR SPEED CONTROLS .....	27
IMPACT RESISTANT FAN GUARDS .....	28
FAN MODELS AND ACCESSORIES SUMMARY .....	29
CEILING FAN SPECIFICATIONS .....	30

## ***PREFACE***

This comprehensive publication contains the only documented, lab tested area coverage data available in the history of commercial/industrial ceiling fans. This guide was compiled to explain in detail the performance characteristics of Leading Edge brand ceiling fans. The contents are written in easy “Layman Terminology” to explain how our fans work so you may confidently make the correct decisions for your fan system.

Test Data Credits: **DR. HAROLD HUGHES**

Virginia Polytech Institute

Additional Data Credit: **DR. FREDERICK ROHLES**

Kansas State University

The information contained in this document is the exclusive property of Leading Edge and may not be duplicated or reprinted in part or entirely without permission. Copyright Leading Edge 1999.

# INTRODUCTION

When the popularity of ceiling fans reappeared during the energy crisis in the late 70's, Leading Edge was the only fan manufacturer to concentrate solely on the commercial/industrial market.

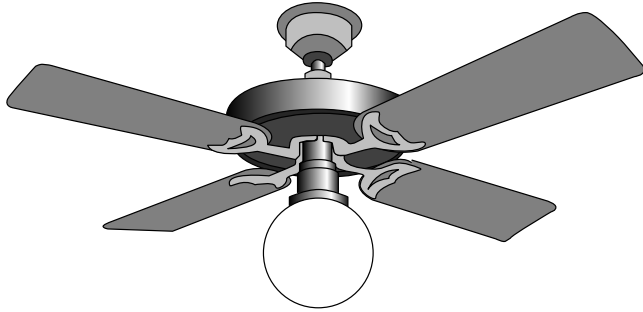

***52" Residential Paddle Fan, Vintage 1896.***

All other ceiling fan manufacturers quickly devoted their full attention to the then booming decorative, residential fan market. As competition heightened the marketing/manufacturing of these flat wooden blade, residential paddle fans quickly became one of price and appearance, not performance. While these fan manufacturers devoted their total efforts toward the residential fan market, Leading Edge developed commercial/industrial ceiling fans for winter heat destratification and summer cooling. In 1978 we designed "AWESOME 60®" the world's first heavy-duty high performance 60" ceiling fan. It's initial success proved we were correct in our direction. We could have stopped there but we didn't. Since then we have continued to design, engineer and manufacture the most complete line of commercial/industrial ceiling fans available. Performance is the primary design and engineering parameter of every model we manufacture.

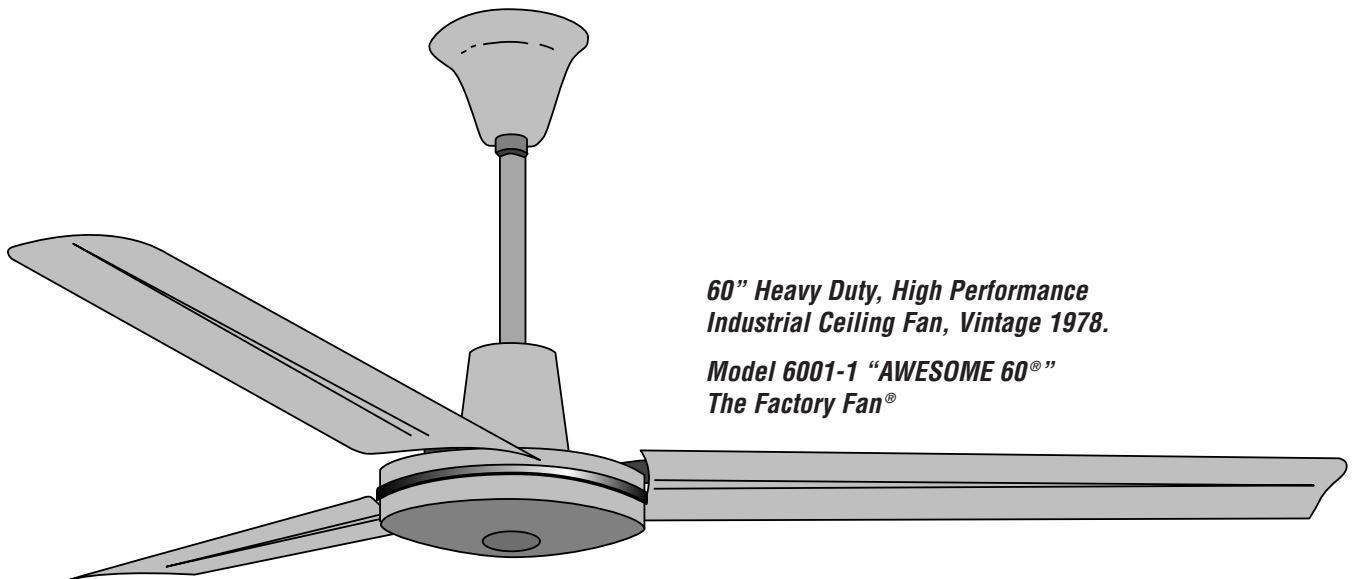

***60" Heavy Duty, High Performance  
Industrial Ceiling Fan, Vintage 1978.***

***Model 6001-1 "AWESOME 60®"  
The Factory Fan®***

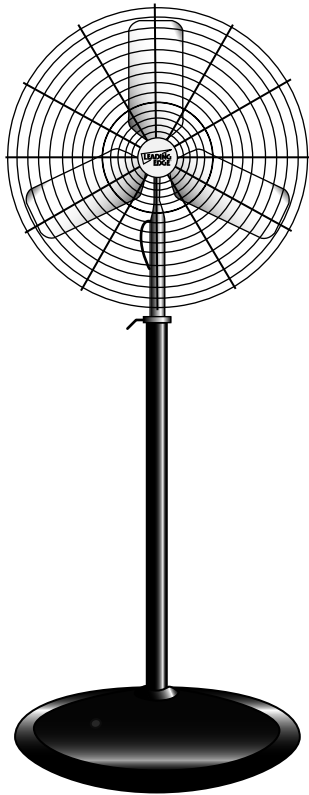

**30" Heavy-Duty - Leading Edge Air Circulator**

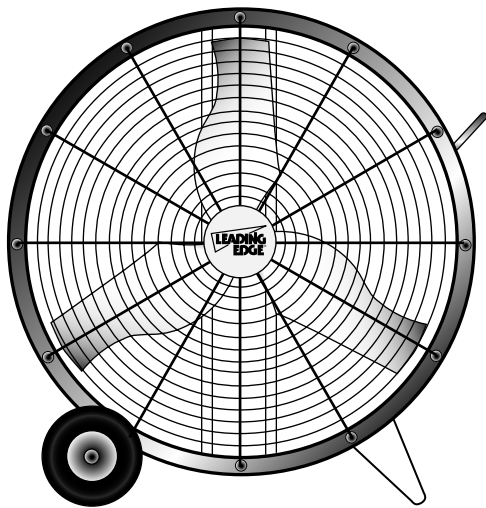

**36" High Volume - Leading Edge Heavy-Duty Direct Drive Air Circulator**

The two most important characteristics of commercial/industrial ceiling fans are HEAVY-DUTY CONSTRUCTION and PERFORMANCE (area coverage). We set the standard for both!

Prior to recently completed laboratory testing (research data enclosed), little or no information was available to help in planning the most efficient ceiling fan system for commercial/industrial applications. The continuing growth of the commercial/industrial ceiling fan market is based on fact not fad. Fan performance is dictated by specific blade and motor laws in all industrial ventilation. The industrial fan buyer must be aware that all fans are not alike; all buildings are not alike. Until now documented performance data was not available.

All other industrial air moving equipment such as exhausters, centrifugal blowers, tube axial fans, ventilators, etc.... are offered with a selection of blade diameters, motor sizes and air movement ratings to suit your individual requirements. To achieve maximum benefits in commercial/industrial ceiling fans these same variables must be considered.

A single model cannot possibly be used to satisfy requirements for all design applications. Leading Edge is the only commercial/industrial ceiling fan manufacturer building a range of five different motor sizes and blade sweep diameters to assure the optimum system.

Because we market worldwide we offer 120, 220, and 277 volt, 50/60 Hz models. We are the first ceiling fan manufacturer to list 50/60 Hz motors with Underwriters Laboratories. Each fan motor is engineered differently to obtain maximum area coverage and performance from a given blade-sweep diameter.

Leading Edge contoured blades are similar in design to large volume industrial air circulators which are also designed for maximum efficiency. In this respect you will never see a flat, curved tip or tapered blade design on industrial circulators... they're just not efficient.

The proof of Leading Edge's/motor/blade design efficiency is reflected in the fan technical data contained herein. No competitor's fan, whether 52", 56" or 60" can match the area coverage of our heavy duty industrial line.

Leading Edge has become the technical leader in the commercial/industrial market now offering a total of 16 different models. The following documented performance data is the first available in our industry to assist your planning.

We could stop here but we won't! New models are on the drawing boards and additional testing and documentation is planned. We understand our fan business ... it's all we do!

# CEILING FAN AIR PATTERNS

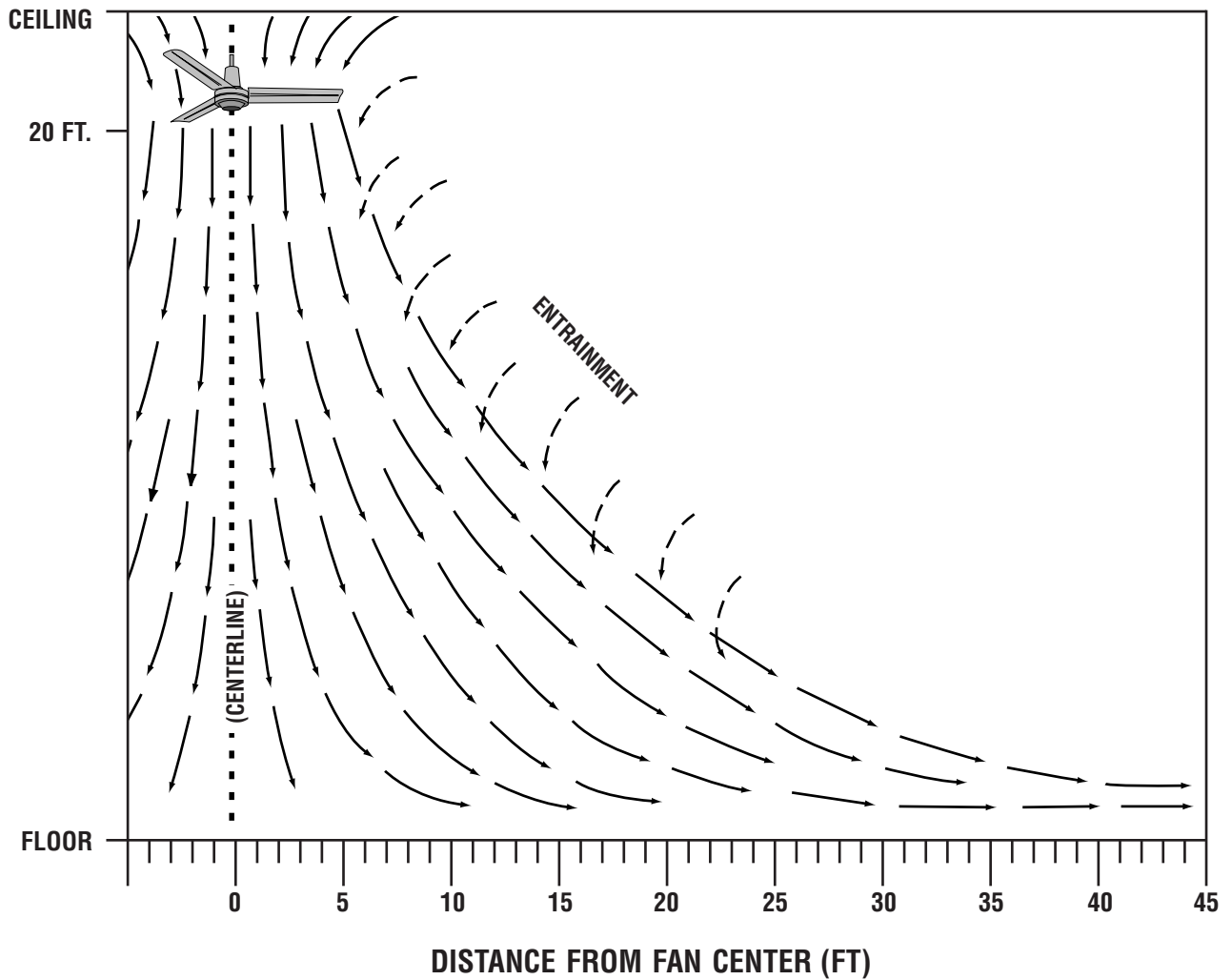

**FIGURE 1**

The above graph (Figure 1) illustrates the performance of Model 6000-1 (60") fan mounted 20 feet (blade height) above the floor.

An air plume is created from the intake air (above the fan) by drawing surrounding ceiling air through the blades. The primary air plume (cone shaped), on the outlet side, is forced downward by the power of this specific motor and blade combination. As the primary air flows downward, surrounding air is entrained, greatly increasing the total air volume. Industrial ceiling fans re-circulate their own air, thus have little effect on a building's positive or negative air pressure.

Total air volume and area coverage is dependent upon specific characteristics such as motor size, blade design/size/rpm as well as fan mounting height. It is for this reason Leading Edge documented specific air flow patterns and area coverage tables of all fan models at various mounting heights.

NOTE: Competitor's published velocity ratings (undocumented) are taken at the face of the fan and are up to three times the actual floor velocity ratings. Velocity decreases as distance from fan increases. No competitor has ever published tested velocity at floor level.

# FAN TEST DESCRIPTION

All Leading Edge fan models as well as fans from competitors were tested during 1985 under identical conditions. All fans were suspended on 24 inch length downrods in the center of a 400 square foot simulated ceiling. Tests were conducted at various blade heights above floor level of 7'1", 10', 20', 30', 40' and 45' (depending upon model).

Velocity readings were taken in 5 foot increments from the vertical centerline (See Figure 1) in all directions. Using 4" vane anemometers at floor level, seventeen

readings were taken per placement. The high and low readings were dropped and the remaining fifteen were averaged to obtain the published results. The inside temperature differential ( $\Delta T$ ) from ceiling-to-floor was 2°F, which is the average  $\Delta T$  range after heat destratification has been achieved. Constant voltage was metered and maintained. All fan RPM's were recorded. The entire testing procedure was video-taped.

See page 7 for details on 24°F  $\Delta T$  and 26°F  $\Delta T$  testing.

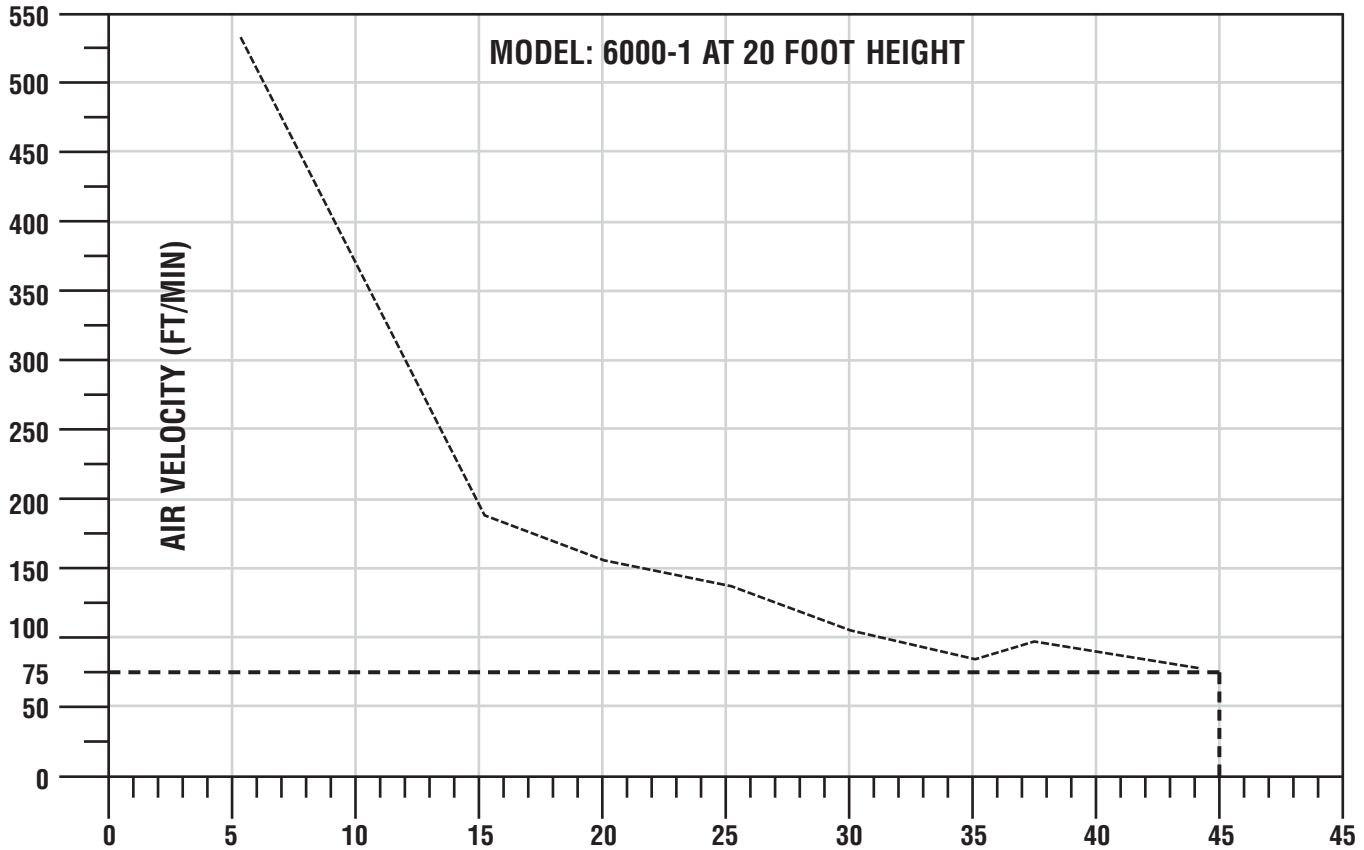

FIGURE 2

## FAN PERFORMANCE DATA

This chart, (Figure 2) reproduces the actual test data performance curves of Model 4C721 (60") fan mounted 20 ft. (blade height) above the floor.

By reading the distance from fan center along the horizontal line, you can determine air velocity at any point from the center of the fan. Refer to the vertical scale for velocity in feet per minute (ft/min). Note that you are measuring the radius from the fan centerline in one direction only. This radius calculation must be doubled for total air pattern diameter (ceiling fans have 3600 air flow coverage).

Example, at 45 ft. from centerline (90' total diameter) this fan produces air velocity of over 75 ft/min. For our calculations we dropped back to the 40 ft. mark for a total area coverage of 5024 square feet ( $\pi r^2 = 3.14 \times 40^2$ ). The square root of 5024 ft. yields a squared area pattern of 70.9 ft. x 70.9 ft. This flow chart proves that even 5 ft. beyond the outer edge of our calculation (40 ft.) we still achieve 75 ft/min air velocity. For our heat recovery calculations we use a cut off velocity of approximately 75 ft/min.

# HOW FANS WORK

## THE LEADING EDGE DUAL PURPOSE ENERGY CONSERVATION SYSTEM

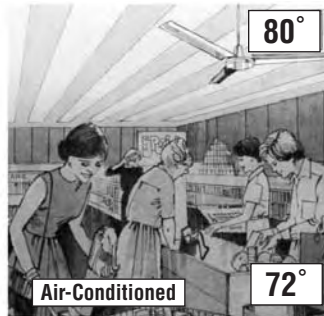
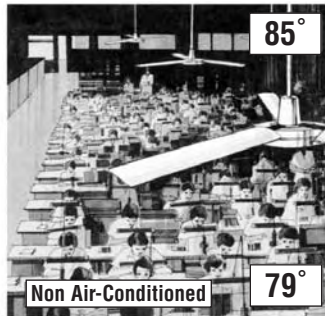
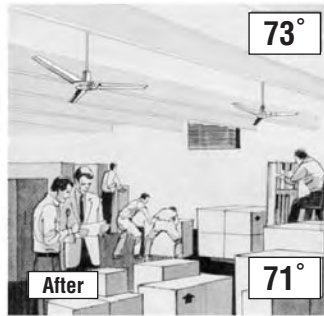
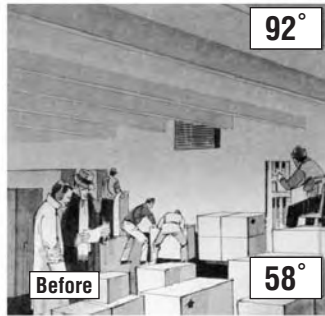

### THE HEAT-DROPPER® CONCEPT AND HOW IT WORKS!

**WINTER** - Recovers wasted heat by eliminating heat stratification. Trapped warm air at the ceiling caused by natural heat rise and poor air circulation is equalized by the movement of the massive blade span. Thus ceiling to floor temperature is equalized. With a heat cost savings of 30 percent, the LEADING EDGE fan system can pay for itself in one year. The elimination of cold spots increases employee productivity and comfort.

**SUMMER** - General air recirculation in non-air-conditioned buildings creates a cooling breeze and a "Wind Chill Factor" providing evaporative cooling of the skin surface dropping skin temperature by 6 degrees. The LEADING EDGE fan system supplements air-conditioned buildings by allowing the thermostat setting to be 8 degrees higher. You'll feel the coolness of 72 degrees with the thermostat set on 80 degrees an incomparable energy savings. Additional advantages, eliminates mold and mildew caused by stagnant air, perfect for high humidity areas. No other fan has our higher air velocity capabilities. Small fans do not develop sufficient CFM to be effective in warm weather.

#### HEAT RECOVERY VS. THE AIR BUOYANCY FACTOR

While everyone agrees that warmer air rises and that large industrial ceiling fans can break up this stratified heat, only one other manufacturer addresses the air buoyancy factor

Practically all substances expand when their temperature is increased, air is no exception. Cooler air, weighing more, sinks to floor level. Warmer, lighter air rises. It is this floating blanket of lighter, warmer air that must be mixed with the heavier floor level air to obtain total vertical equalization of temperatures and greatest energy cost savings.

To counteract this natural buoyancy force, it takes an efficient, powerful, heavy duty fan moving large volumes of warm air at an initial high downward velocity. A less powerful fan may not break this buoyancy effect and, therefore, total destratification will not be achieved. It must also be noted that for this reason reversing fans cannot possibly function in the heat destratification process in spacious areas.

Leading Edge fan performance and destratification capabilities have been documented at heights exceeding 75 ft. with initial ceiling-to-floor temperature differentials exceeding 26°F AT with a recorded, 2°F AT after an initial 30 minutes of operation. During the 1985 January ASHRAE Exhibition at McCormick Place, Chicago, we recorded a 24°F AT in our exhibit area prior to operating our fan. One model 6000-1, mounted 48 ft. above floor level, successfully destratified this area with a recorded floor temperature 22°F higher than surrounding areas. Area coverage of over 35 ft. from fan centerline was measured and demonstrated to those in attendance. Less powerful fans simply cannot break up the air buoyancy (AT) factor and achieve this heat destratification. No other ceiling fan manufacturer has ever demonstrated this

feat before. We proved it to the most prestigious engineering gathering in the world.

#### COOLING APPLICATIONS

Several factors must be considered regarding the use of industrial fans for summer cooling.

The results of extensive research testing conducted by Dr. Frederick Rohles of Kansas State University, Environmental Department, proves the validity of this statement. He states that in a non-airconditioned area, air velocities in the range of 90 to 200 feet per minute are required to extend the upper limit of the summer comfort envelope by as much as six degrees.

Only Leading Edge fans are designed for both winter and summer operation. Our fans develop both maximum velocity and area coverage. Smaller capacity fans are incapable of producing even the minimal requirement of 90 feet per minute in an area directly under the fans. Leading Edge fans are designed as year round, dual purpose products.

Under most summer conditions the use of industrial ceiling fans in non-airconditioned areas for ventilation and evaporative cooling is advisable. In those application where a facility with high temperature ceilings exist, it is advisable to select our reversing model, (see page 22) to be used as a supplemental fan to existing exhaust fans or ridge vent openings.

As a Florida based corporation, we have "hands on" experience with our high summer temperatures. As an example, model 6000-1 was designed specifically for both winter heat destratification and summer cooling.

# BLADE AND MOTOR DESIGNS

*“All Fans Are Not Alike!”*

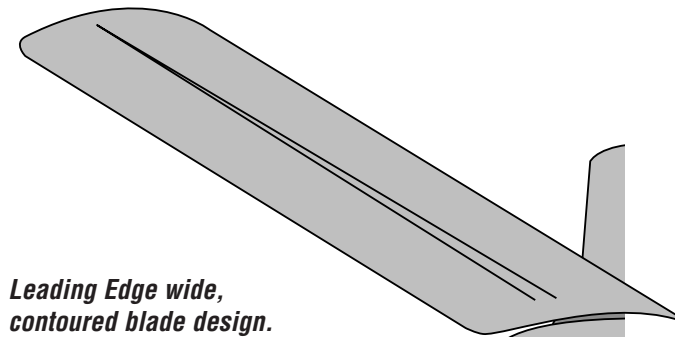

***Leading Edge wide,  
contoured blade design.***

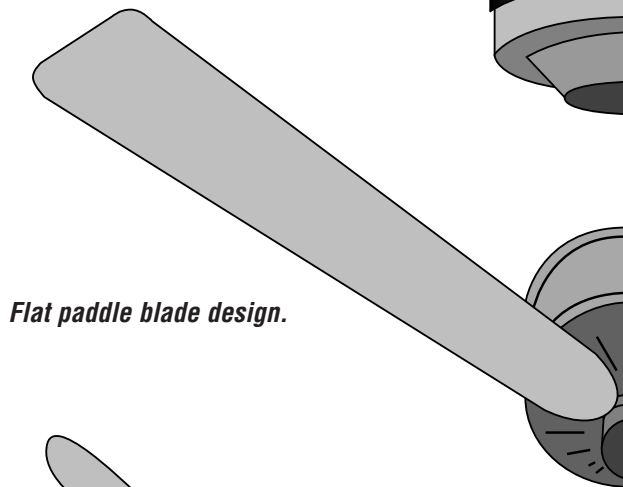

***Flat paddle blade design.***

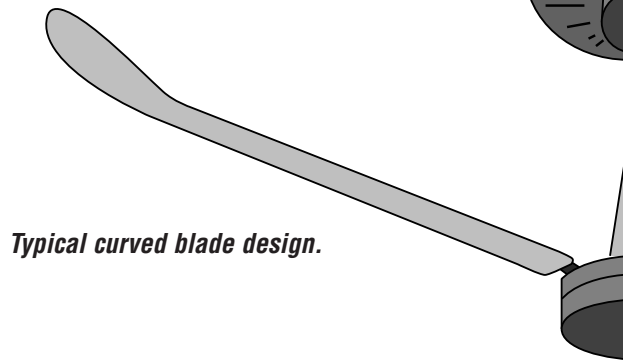

***Typical curved blade design.***

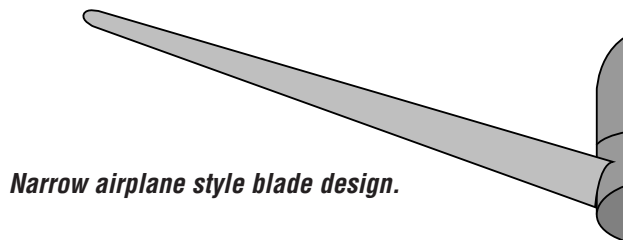

***Narrow airplane style blade design.***

Blade designs and resulting air delivery involves a complex interplay of factors such as diameter, pitch, tip speed, motor size and related RPM and number of blades.

Change one and it effects all the others. Our contoured shaped wide blade design is the most efficient of all designs we have tested. The key in performance is the match of a given power motor and blade sweep to achieve the desired RPM and velocity.

By testing and analyzing competitor blade designs and resulting performance, we determined that the flat paddle blade (residential) literally “skips” thru the air with little drag and downward thrust. Thus, regardless of RPM, minimal air delivery and area coverage is achieved in open, spacious areas.

The curved tip blade design originated in England in the early 1900’s as a decorative treatment for a metal blade residential fan. Contrary to competitor’s published statements, that the curved tip “Throws a wider beam of air,” both our smoke and instrument testing proves this statement false. In reality the flat, metal blade fans with curved tips produces no additional air delivery at the outer edge of the blade span as the curved tip free-wheels. The blade pitch is greatly reduced from one competitor model to another to achieve desired RPM with relatively small motors.

The relatively narrow, airplane style propeller design is great for airplanes moving thru the air, but not as efficient for a stationary fan moving air thru the blades. Although this design allows for high RPM, it does not match the same area coverage of the Leading Edge wide, contoured blade at the same RPM. Our wider, full contoured blade design has a greater angle of attack and subsequent wider throw of air.

If our blade design is so efficient why don’t competitors use our style blades? Answer! They can’t... because it takes a more powerful motor. They use the same small size motors that power their 52” and 48” residential paddle fans. Due to the extreme competition in the residential fan market, motor sizes have been reduced by 50 percent during the last 7 years in an effort to build a less expensive fan for mass market residential consumers.

Leading Edge does not manufacture residential ceiling fans! We build the most powerful and efficient industrial ceiling fan motors in the industry.

The formula that determines the power capable of being delivered by a given electric motor is  $P = D^2 L$ . This means simply the square of the diameter (of the stator) multiplied by the stack height of the motor. As stated, Leading Edge builds the most powerful, efficient\* industrial ceiling fan motors available!

An easier understood comparison of power to performance is by comparing the sizes of general purpose

incandescent lamps. Although all light bulbs appear similar... they're not. All ceiling fans may appear similar... they're not!

The total amount of light produced by a light source is measured in lumens. When one lumen of light falls on an area exactly one square foot, that area is said to be lighted at one foot-candle. Compare the watts and corresponding lumens value on each bulb.

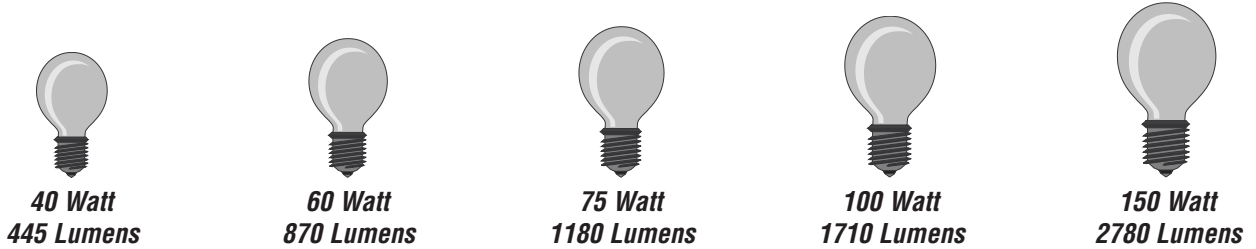

Now compare watts of specific motors from competitors and their claimed performance. In factory installations the low watt, inexpensive light bulb doesn't save electricity ... you have to install three times as many 60 watt bulbs to achieve the lighting value of a single 150 watt light bulb. With fans, you would have to purchase and install three 75 watt fans to achieve the area coverage of a single 160 watt model 6000-1 ; you still may not have sufficient power to overcome high temperature differential (See Page 7).

There is no "magic" in the formula of electric ceiling fan motor design, "Designed Power is Designed Performance" All documentation proves this statement. We could have easily put 56" competitor style blades on our 75 watt motor as others do. One competitor even has a 60" sweep on a 58 watt motor. The desired velocity and area coverage would simply not be achieved in this method of blade/motor selection.

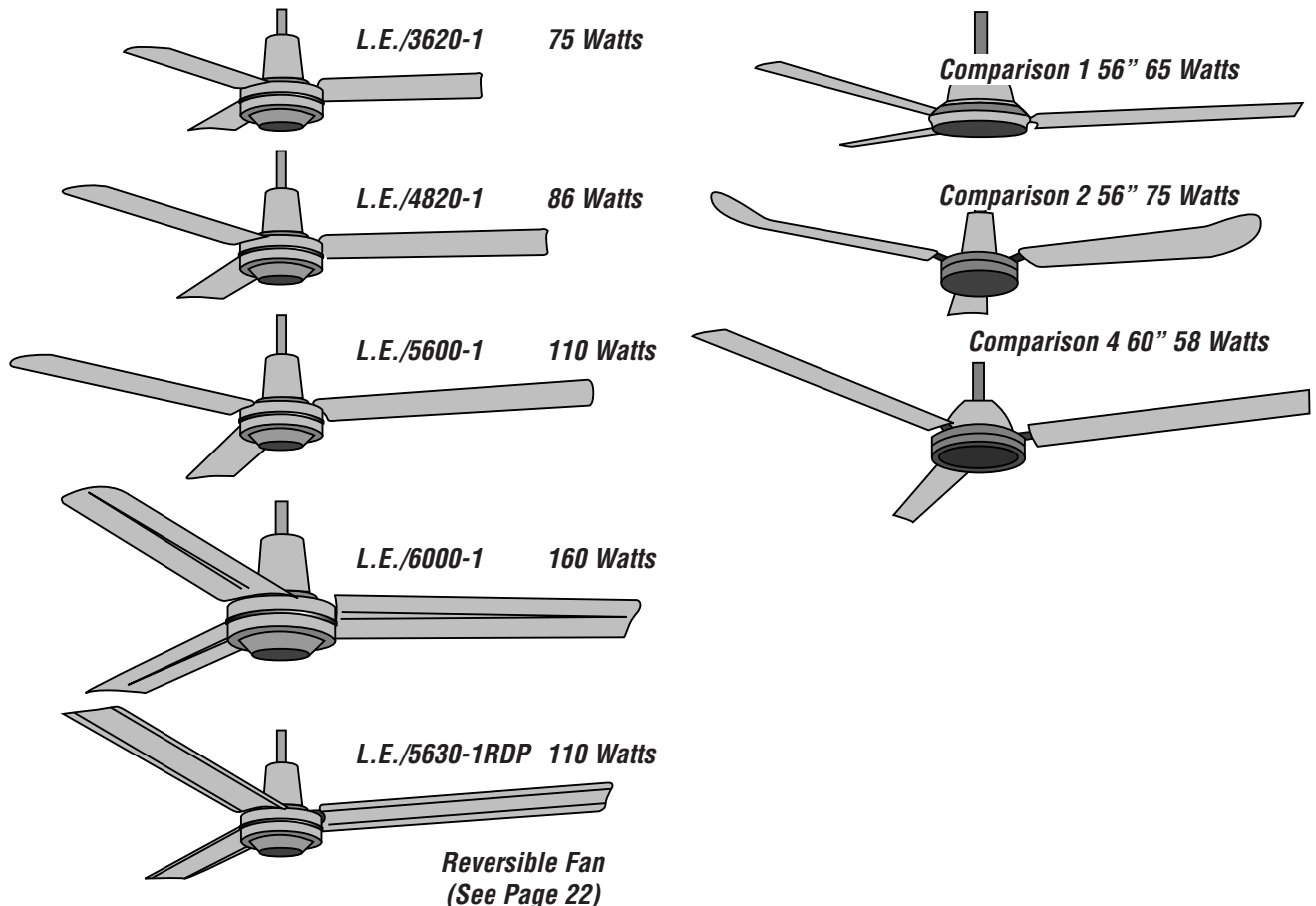

# CAPITOL COST COMPARISON THE LEADING EDGE ADVANTAGE

*Lowest Total Installed Cost Per Square Foot*

We have always treated ceiling fans as a system, not as single units. This fact is not revolutionary, but rather a common sense approach to selection of any industrial equipment from lighting to general ventilation. By analysis of fan data we offer the lowest total installed cost system on a per square foot basis.

The average published formula of the fans from competitors is one fan per 2,000 square feet (ft.2) (non-documented) at a 20 foot mounting height. Because our motor and blade designs are more efficient, our documented area coverage is up to 3 1/2 times that of the average competitor's claim. The cost of installation per fan must be considered. This cost factor per fan is constant regardless of which fan you purchase. In many instances, installation cost per unit will meet or exceed the purchase price of the fan.

Because Leading Edge fans provide larger area coverage, you require fewer fans to perform the same function. Substantial savings are realized on the total installed cost of your system.

For example, the following diagram (Figure 3) of a 58,800 ft.2 facility shows a total of 12 model 6000-1 fans (rated at 5,000 ft.2 per fan). The "Brand X" fan (rated at 2,100 ft.2 per fan) required 28 units to cover the same area. Remember the installation cost is the same on both fans.

By using a basic and easy to compute capital cost comparison formula you can calculate your own savings as follows:

<b>Leading Edge Model</b>	<b>Brand X Model</b>
---------------------------	----------------------

Total square foot area to be covered,

A, \_\_\_\_\_ ft.<sup>2</sup>    A, \_\_\_\_\_ ft.<sup>2</sup>

Area coverage per fan,

B, \_\_\_\_\_ ft.<sup>2</sup>    B, \_\_\_\_\_ ft.<sup>2</sup>

The total fan units required,

A ÷ B=C, \_\_\_\_\_    A ÷ B=C, \_\_\_\_\_

Compute fan unit cost,

D, \$ \_\_\_\_\_    D, \$ \_\_\_\_\_

Compute installation cost,

E, \$ \_\_\_\_\_    E, \$ \_\_\_\_\_

Total Installed Cost =

T.I.C. = (D + E)xC, \$ \_\_\_\_\_    T.I.C. = (D + E)xC, \$ \_\_\_\_\_

An extreme example would be the use of discount store or home center promotional \$49.95 fans. Lets assume these imported 56" curved tipped patio fans could overcome the AT buoyancy factor and could cover 900 ft.2 per fan. The result is that 65 fans would have to be installed and no summertime cooling would be achieved. The low priced fan with its hidden additional costs is no bargain.

Residential patio fans are commonly rated at 400 ft.2 per fan (20'x 20' Living Room 8' tall ceiling).

# FAN PLACEMENT COMPARISON

**Figure 3** is a 58,800 ft.<sup>2</sup> facility with a 22 foot clear ceiling height. By using model 6000-1 rated at 5,000 ft.<sup>2</sup> area coverage per fan, you require a total of 12 fans for your system ( $58,800 \div 5,000 = 12$ ). These twelve fans are indicated in the center of each solid line square. By using the Brand X fan rated at 2,100 ft.<sup>2</sup> per fan, you require a total of 28 fans ( $58,800 \div 2,100 = 28$ ). Refer to the "X" in the center of the dotted blocks. (We rounded off to 30 fans for placement uniformity.)

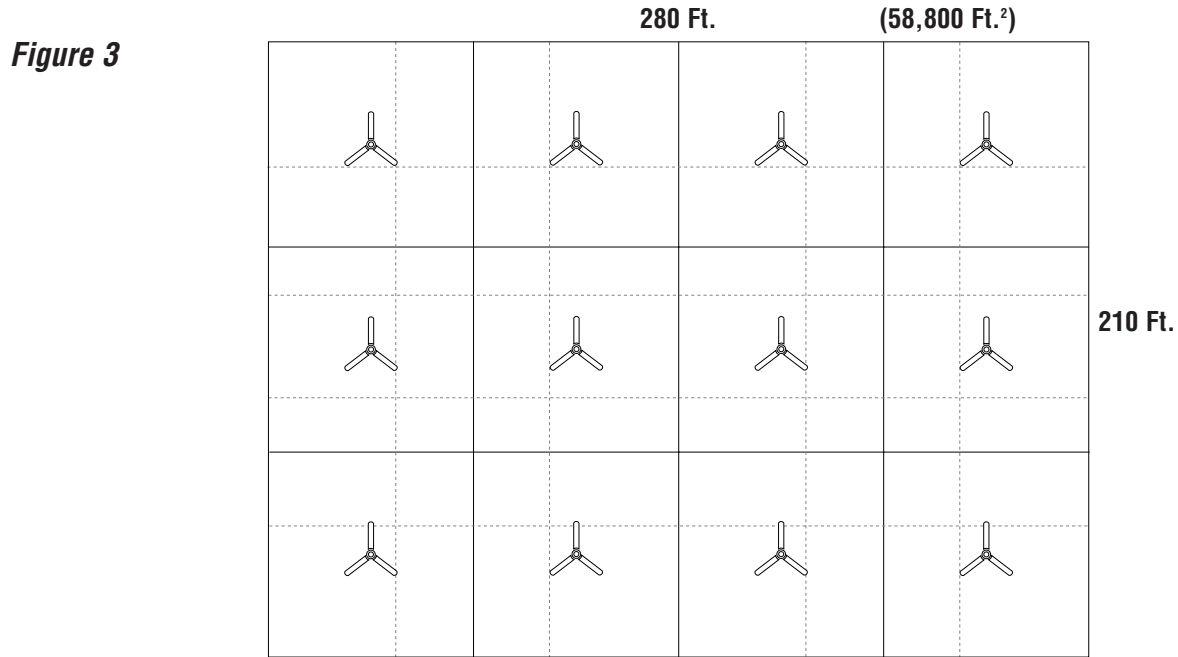

An extreme example would be the use of any fan rated at 1,400 ft.<sup>2</sup> area coverage per fan. Figure 4 shows a total of 42 fans ( $58,800 \div 1,400 = 42$ ). Note both buildings are identical and a comparison is 12 model 6000-1 to the 42 Brand Y. A further comparison would be any fan rated at 900 ft.<sup>2</sup> per fan would require 65 fans in this building.



# TRUTH IN TESTING

## LEADING EDGE FANS

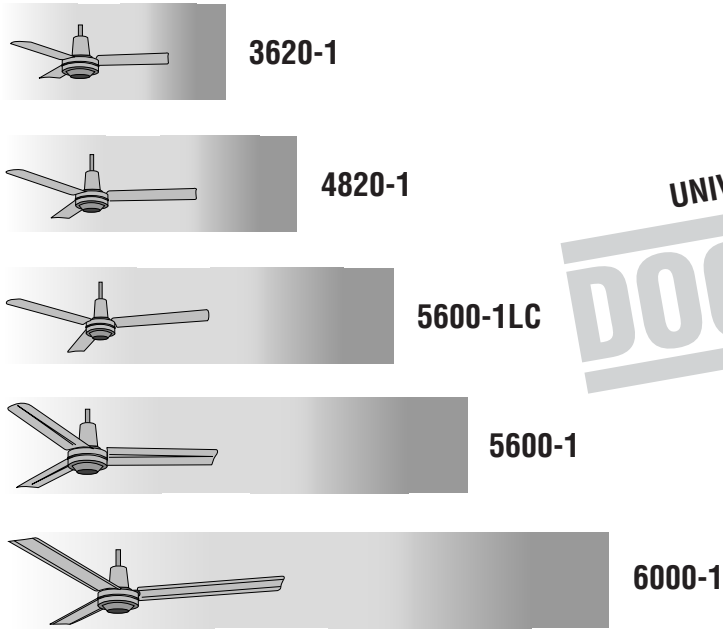

UNIVERSITY TESTED AND FULLY  
**DOCUMENTED**

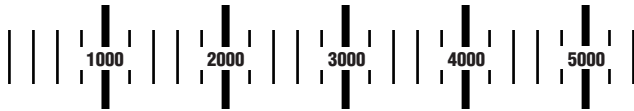

TOTAL SQUARE FOOT AREA COVERAGE

## COMPETITOR FANS

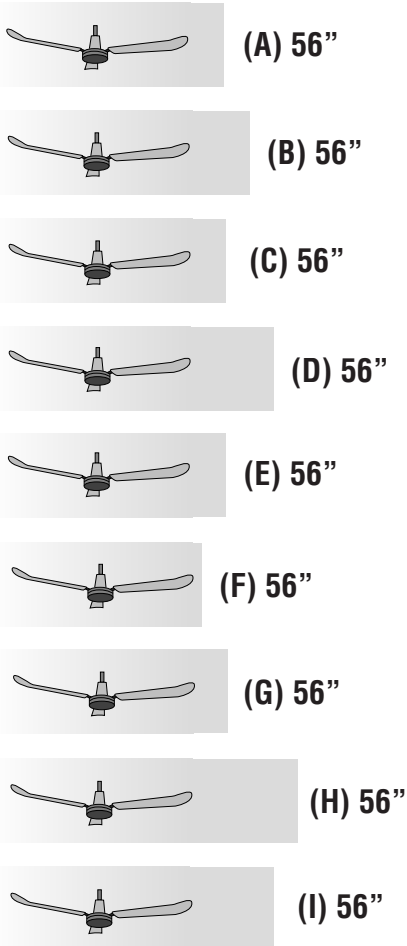

### TESTED BUT NOT DOCUMENTED

The designs and component parts of competitor models are virtually identical. In fact, many originate from the same foreign manufacturer.

Almost all fans are powered by the same relatively small 75 watt motors that are normally used in 48" diameter residential style four wooden blade paddle fans. All competitor models shown use almost identical design 56" curved tip metal blades.

Although competitors claim their 56" curved tip blade design delivers a cone shaped air pattern, actual field testing proves otherwise.

Contrary to claims, the curved tip portion of the blade produces no outward air delivery when tested. The curves tip portion of the blade creates minimal resistance and performance.

The combination of small sized electric motors, inefficient blade design with relatively minor blade pitch angle creates minimal air delivery and square foot area coverage.

*It must be noted that performance claims, although not documented, appear virtually identical.*

# ESTIMATING ANNUAL SAVINGS FOR HEAT RECOVERY

This calculation formula is based upon the reduction of heat loss by decreasing the temperature differential ceiling to floor. Sidewall losses are not considered because it is assumed the average loss over the wall's height will remain the same with a heated air

redistribution system. This calculation assumes constant thermostat settings during the heating season. If thermostat setback is used, adjust accordingly, using ASHRAE calculation methods.

## LOCATE:

① Fuel Factor	(Table 1)	<u>144,000</u>
② Seasonal Efficiency	(Table 2)	<u>.65</u>
③ Heat Loss Factor	(Table 3)	<u>.23</u>
④ Roof Pitch Factor	(Table 4)	<u>1.01</u>
⑤ Average Heating Season Temperature	(Table 5)	<u>35.8 F°</u>

## MEASURE:

⑥ Inside Ceiling Air Temperature	<u>80 F°</u>
⑦ Floor Air Temperature	<u>60 F°</u>

## CALCULATE:

⑧ Roof Area  $\frac{240}{\text{LENGTH}} \times \frac{240}{\text{WIDTH}} \times \frac{240}{\text{ROOF PITCH FACTOR}} = \underline{43,632}$  sq. ft.

TEMPERATURE DIFFERENCE  
Before Installation

$\Delta T_b = \text{⑥} - \text{⑤}, \text{⑥ } 80 - \text{⑤ } 35.8 = \underline{44.2 F°}$

TEMPERATURE DIFFERENCE  
After Installation

$\Delta T_a = \frac{\text{⑥} + \text{⑦}}{2} - \text{⑤}, \frac{\text{⑥ } 80 + \text{⑦ } 60}{2} - \text{⑤ } 35.8 = \underline{34.2 F°}$

## ENERGY SAVINGS CALCULATION:

HEAT LOSS BEFORE

$HLB = \text{③} \times \text{⑧} \times \Delta T_b, \text{③ } .23 \times \text{⑧ } 43,632 \times \text{④ } 44.2 F° = \underline{443,563}$  BTU/hr

HEAT LOSS AFTER

$HLA = \text{③} \times \text{⑧} \times \Delta T_a, \text{③ } .23 \times \text{⑧ } 43,632 \times \text{④ } 34.2 F° = \underline{443,563}$  BTU/hr

Fuel Saved =  $\frac{HLB - HLA}{\text{①} \times \text{②}} \times 5088$  Heating Season Hours

$\underline{44,563} - \underline{343,209} = \text{(A) } \underline{100,354}$

$\text{① } \underline{144,000} - \text{② } \underline{.65} = \text{(B) } \underline{93,600}$

$\text{(A) } \underline{100,354} \div \text{(B) } \underline{93,600} \times 5088 =$

$\text{© } \underline{5,455}$  Gal. Oil/yr.  
Cu. ft. Gas/yr.  
kwh/yr.

Annual Dollar Savings - (Multiply by fuel cost per unit) -  $\text{(©) } \underline{5,455} \times \underline{\$1.10/\text{Gal}} = \underline{\$6,000}$  yr.

Example used in calculation is 43,632 sq. ft. building, oil heat, Chicago, IL.

**TABLE 1 - FUEL FACTOR**

TYPE OF FUEL	FUEL FACTOR
OIL	144,000 BTU/GAL
GAS	800 BTU/FT <sup>3</sup>
ELECTRIC	3415 BTU/KWH

**TABLE 2 - SEASONAL HEATING EFFICIENCY**

TYPE OF FUEL	EFFICIENCY
OIL	.65
GAS	.70
ELECTRIC	1.00

**TABLE 3 - HEAT LOSS FACTOR**

$$\left( \frac{\text{BTU}}{\text{Hr. ft.}^2 \text{ F}^\circ} \right)$$

ROOF CONSTRUCTION	UNINSULATED FACTOR	2" INSULATED FACTOR
SLAB 4" ROOFING*	.23	.11
WOOD 2" ROOFING*	.22	.10
METAL ROOFING*	.40	.13
METAL ROOFING	.90	.16

**TABLE 4 - ROOF PITCH FACTOR**

PITCH	PITCH FACTOR
FLAT	1.00
2:12	1.01
4:12	1.05
6:12	1.12

NOTES: ASHRAE guide states that the vertical temperature gradient (heat rise) can be assumed to be 0.75 °F per foot of plant height when the difference between indoor and outdoor temperature is 75°F.

Certain types of heating systems, as well as various building size and will result in significantly greater

**TABLE 5 - LOCAL HEATING DATA**

LOCATION	AVERAGE HEATING SEASON TEMPERATURE F°
ARIZONA - FLAGSTAFF	35.6
COLORADO - DENVER	40.8
CONNECTICUT - HARTFORD	37.3
DELAWARE - WILMINGTON	42.5
WASHINGTON, D.C.	45.7
IDAHO - BOISE	39.7
ILLINOIS - CHICAGO	35.8
INDIANA - INDIANAPOLIS	39.6
IOWA - DES MOINES	35.5
KANSAS - TOPEKA	41.7
KENTUCKY - LOUISVILLE	44.0
MAINE - PORTLAND	33.0
MARYLAND - BALTIMORE	46.2
MASSACHUSETTS - BOSTON	40.0
MICHIGAN - DETROIT	37.2
MINNESOTA - MINNEAPOLIS	26.3
MISSOURI - KANSAS CITY	43.9
MONTANA - HELENA	31.1
NEBRASKA - LINCOLN	38.8
NEVADA - ELKO	34.0
NEW HAMPSHIRE - CONCORD	33.0
NEW JERSEY - TRENTON	42.4
NEW MEXICO - ALBUQUERQUE	45.0
NEW YORK - ALBANY	37.2
NEW YORK - BUFFALO	34.5
NEW YORK - NEW YORK CITY	42.8
NORTH DAKOTA - BISMARCK	26.6
OHIO - COLUMBUS	39.7
OREGON - PORTLAND	47.4
PENNSYLVANIA - HARRISBURG	41.2
PENNSYLVANIA - PHILADELPHIA	44.5
PENNSYLVANIA - SCRANTON	37.7
RHODE ISLAND - SIOUX FALLS	38.8
SOUTH DAKOTA - SIOUX FALLS	30.6
UTAH - SALT LAKE CITY	38.4
VERMONT - BURLINGTON	29.4
WASHINGTON - SEATTLE	46.9
WEST VIRGINIA - CHARLESTON	44.8
WISCONSIN - GREEN BAY	30.3
WYOMING - CHEYENNE	34.2

ceiling-to-floor temperature differentials.

This formula does not take into account the additional heat gain generated from industrial processing equipment, which could alter the ceiling air temperature drastically.

# The Anatomy Of A LEADING EDGE Industrial Ceiling Fan.

Fan Shown Actual Size (Model 6000-1)

Engineered specifically  
for commercial and  
industrial applications.  E130778  
Unsurpassed for performance,  
efficiency and reliability.

**DOWNROD ASSEMBLY** -  
24" Length, heavy duty,  
13/16" O.D. steel pipe.

**ROD BOLTS** -  
(Hi-tensile/special shank)  
1 1/2" length hex nut/split  
pin locking assembly.

**YOKE** -  
1/8" specially formed  
plated steel, shock  
absorbing.

**HOUSING** -  
Deep drawn,  
abundant airspace  
for heat dissipation.

**CEILING FAN** -  
Suitable for use with solid  
state speed controls.

**HEAVY DUTY BLADE  
MOUNTING BRACKET** -  
Custom formed hi-tensile  
steel 3 point suspension.

**BLADE SCREWS** -  
Extra long cadmium  
plated hex screws.

**BLADES** -  
Hi-performance  
aerodynamically  
contoured blade design.

**COIL** -  
18 Pole electronically  
wound, enameled  
copper wire, vacuum -  
impregnated with  
synthetic varnish.

**ROTOR** -  
High grade electrical  
stacked laminations,  
precision balanced to  
insure wobble-free  
operations.

**BEARINGS** -  
Heavy duty, permanently sealed and  
greased chrome steel ball bearings  
for maintenance-free performance.

**FINISH** -  
Corrosion resistant  
white epoxy enamel,  
electrostatically  
applied epoxy  
powder primer.

## Unsurpassed Features of Leading Edge Commercial/Industrial Coiling Fans.

**SEAL -**  
Neoprene rod seal.

**CAPACITOR -**  
Non polar weatherproof encapsulated extra heavy duty 9.5 MFD. (Contains no P.C.B. materials).

**WIRING -**  
18 AWG  
"3 conductor"  
motor leads.

- Engineered specifically for commercial and industrial applications.
- Energy-efficient, totally enclosed motors, the largest and most powerful available.
- Aerodynamically contoured heavy-duty blade design provides maximum area coverage, will not warp in high temperatures.
- The highest rated area coverage per fan model.
- Perfectly balanced motor and blades for wobble-free performance.
- Blade sets weight matched to within 2 grams tolerance.
- Thermal-overload protection, (Texas Instruments) built-in, self-resetting, a new U.L. requirement for fans using solid state motor speed controls.
- Permanently sealed and greased bearings for maintenance-free whisper quiet operation.
- Corrosion resistant, durable epoxy enamel paint finish over electrostatically applied powdered primer base.
- Dual purpose, designed for both heat reclamation and warm weather cooling.

**THERMAL PROTECTOR -**  
Texas Instruments 9700, resets automatically. A U.L. requirement on all fans using solid state motor speed controls.

**HEAVY DUTY UPPER SHACKLE -**  
Rubber bushed for "floating suspension" locknut and pin for safety.

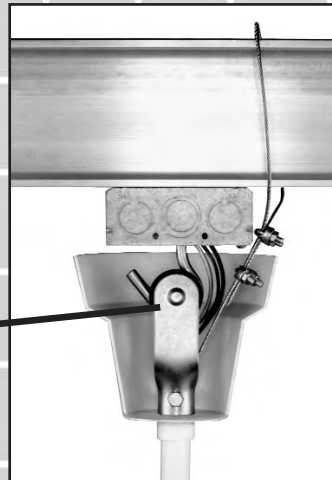

**"SECONDARY SUPPORT CABLE"**  
6' Length of heavy-duty 7x7 1/8" galvanized cable with rated breaking strength of 1700 lbs. Pre-installed directly to permanent motor shaft for maximum protection and easy installation. CSA (Canadian Standards Association) listed (Standard C22.2 Sept. 1986).

**OUTER RING -**  
Chrome plated (ABS plastic).

**BLADES -**  
Aerodynamically contoured blade design for greater air delivery.

**STATOR -**  
High grade electrical steel laminations, extreme close tolerance eliminates air space between plates, varnish dipped.

**SLOT INSULATION -**  
Mylar (Polyester).

**SHAFT -**  
Cold-drawn, steel rod bar 11/16"

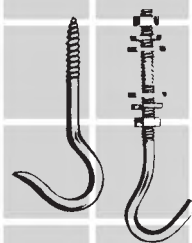

**J-HOOKS -**  
Heavy duty "J" hook for wooden beams and "J" bolt (3/8" thread for steel beams) 6" length are included with each fan.

# LEADING EDGE HEAVY DUTY COMMERCIAL AND SPECIAL APPLICATION CEILING FAN DATA

Provides Superior Air Velocity and Efficiency, The Ideal School Classroom Fans (Models 48" and 56").

## 3620-1/ 36" Commercial Fan

Designed for smaller areas, where minimal ventilation is required. Ideally suited for isolated areas and as a supplemental cooling fan.

## 4820-1/ 48" Commercial Fan

Designed for commercial facilities such as school classrooms, offices, retail stores, restaurants. Provides maximum area coverage for both summer cooling and winter heat destratification.

## 5600-1LC/ 56" Commercial / School Classroom Fan

Designed for spacious areas with low ceilings where larger blade diameter span creates maximum air velocity and area coverage at lower RPM's. Engineered specifically for continuous commercial use with the same manufacturing criteria as our heavy duty industrial line. Ideally suited for classrooms.



Suitable for low ceiling applications. U.L. 507 listed.

Suitable for low ceiling applications. U.L. 507 listed.

Suitable for low ceiling applications. U.L. 507 listed.

U.L. 507 states ceiling fans suspended from 7 feet to less than 10 feet (blade height to floor) must have minimum thickness of edge of blade 3/16".

UNITED STATES PATENT NUMBERS 5,645,403

## 4820-3/ 48" - 5600-3/ 56" 3-Speed Pull Chain

For spot cooling in areas where wall switches are not desired. Also designed for production areas where single unit designation operation is required.

### HEAVY DUTY COMMERCIAL MODELS

MODEL NUMBER	BLADE SWEEP	COLOR	VOLTS	CYCLE	FULL LOAD AMPS	FULL LOAD WATTS	RPM	MAX CFM*	AREA COVERAGE PER FAN**	WEIGHT
3620-1	36"	WHT	120	50/60	.65	75	395	12,500	1600 sq.ft.	20 lbs
4820-1	48"	WHT	120	50/60	.85	86	315	21,000	2025 sq.ft.	22 lbs
5600-1LC	56"	WHT	120	50/60	1.0	110	265	25,500	3025 sq.ft.	24 lbs

### SPECIAL APPLICATION MODELS

4820-1B	48"	BLACK	120	50/60	.85	86	315	21,000	2025 sq.ft.	22 lbs
4820-3*	48"	WHT	120	50/60	.85	86	315	21,000	2025 sq.ft.	23 lbs
5600-3*	56"	WHT	120	50/60	1.0	110	265	25,500	3025 sq.ft.	26 lbs

\*3-Speed Pull Chain

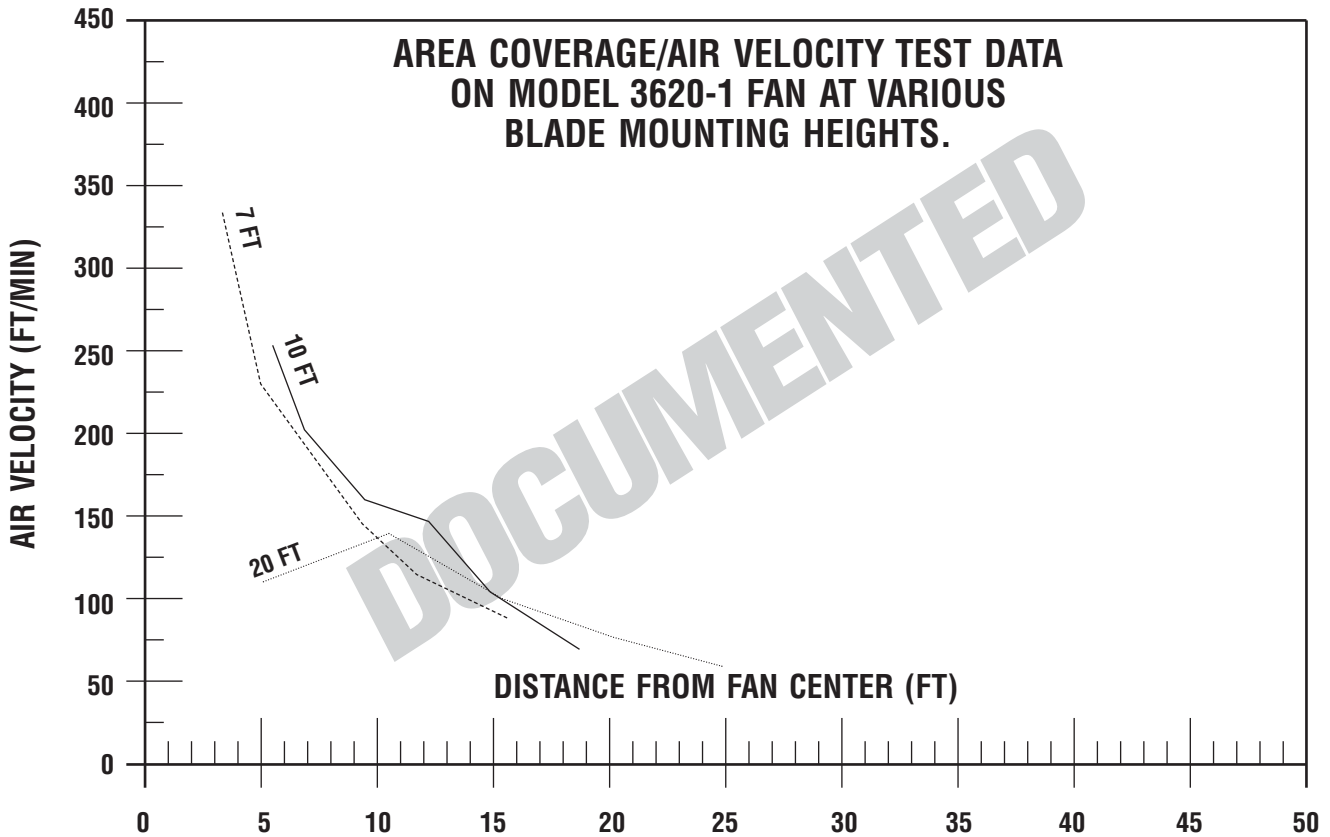

Figure 6

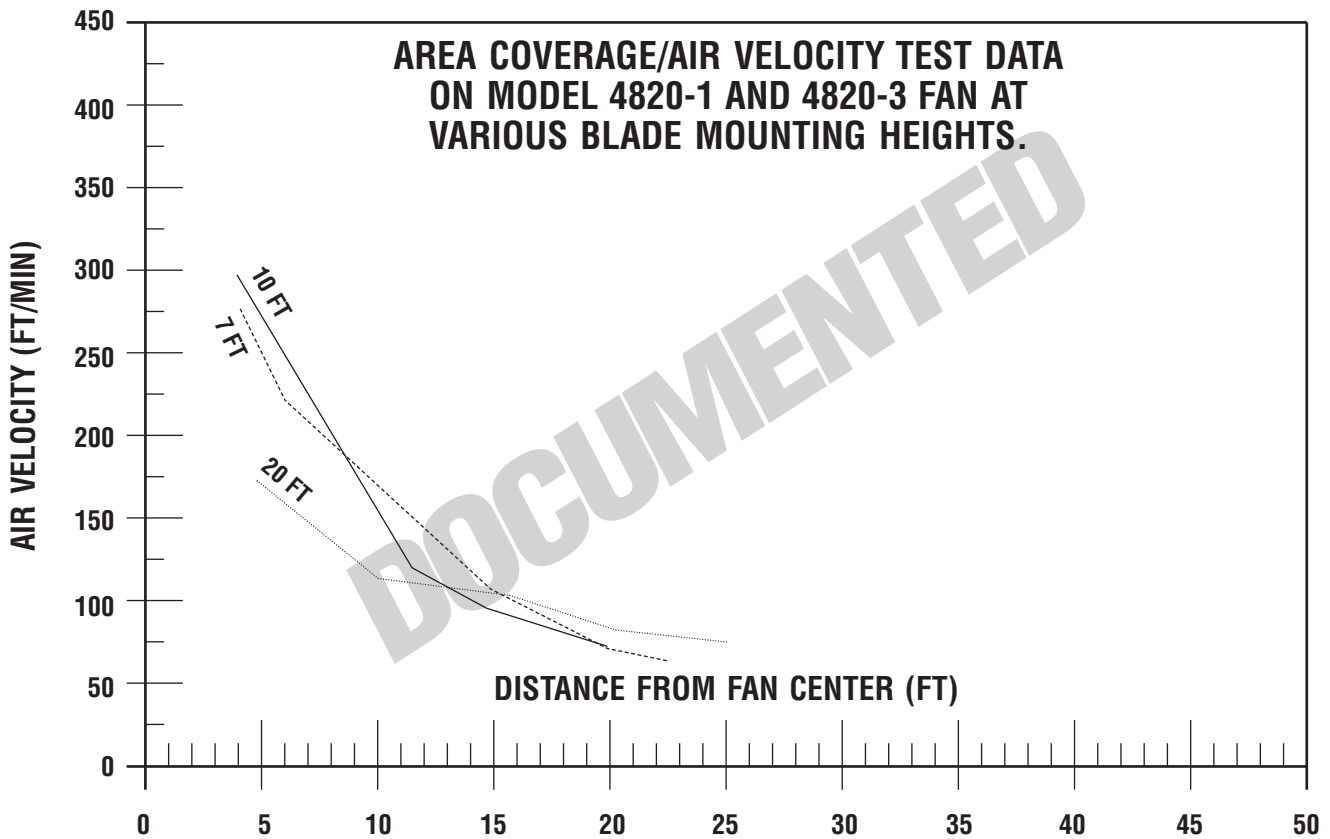
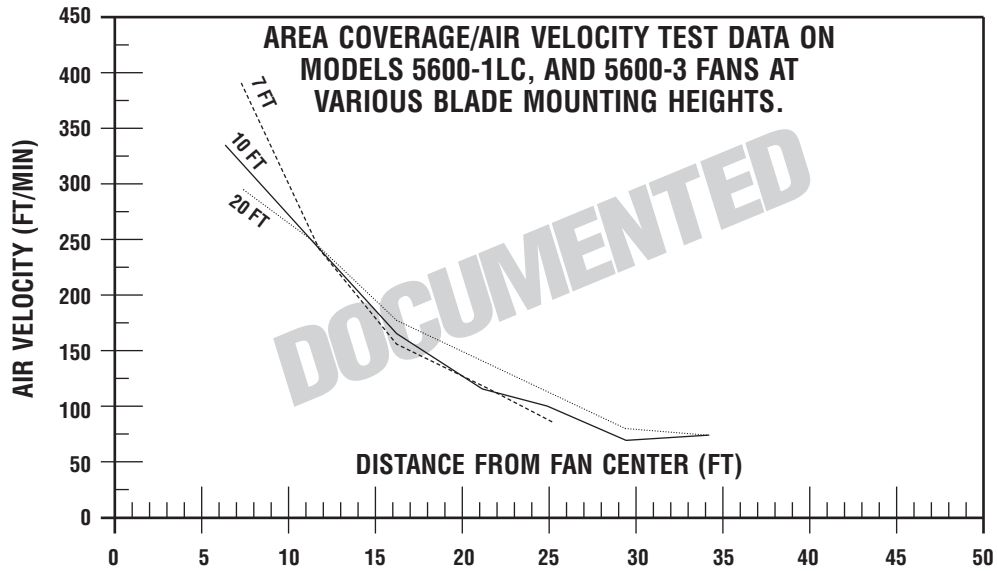
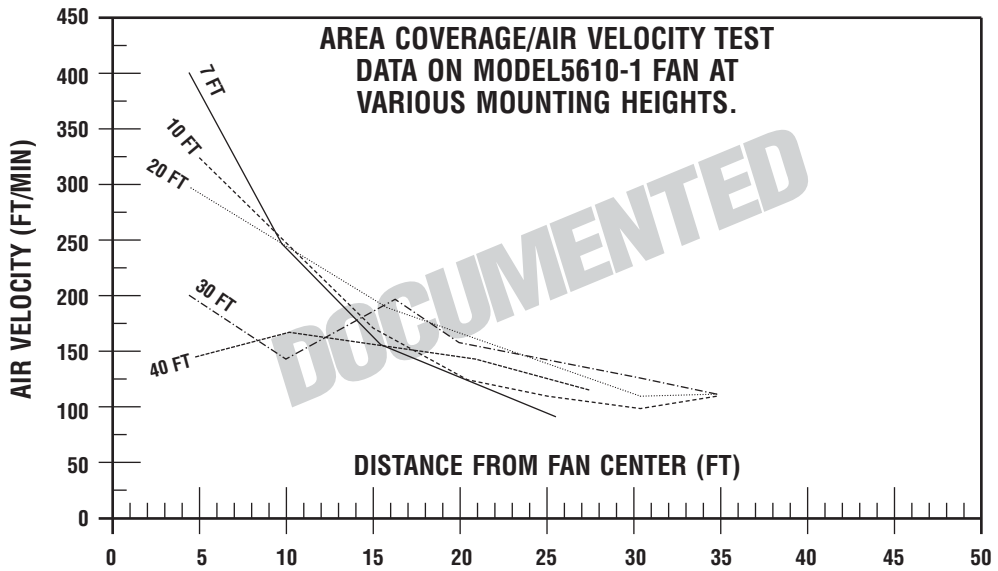

Figure 7



**Figure 9**



**Figure 9A\***

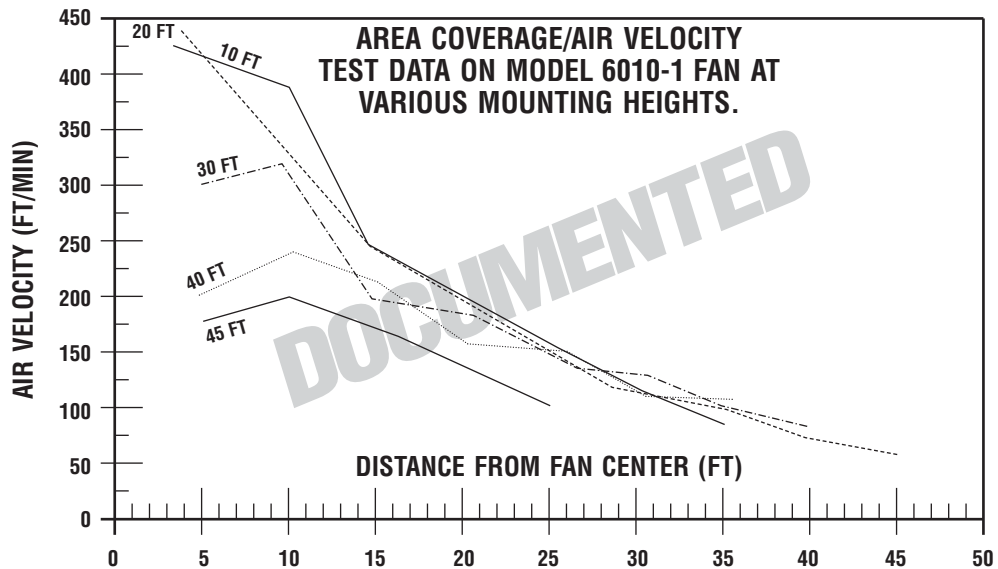

**Figure 9A\***

\*For further data on these two models refer to page 27

# HEAVY DUTY COMMERCIAL MODELS

## AREA COVERAGE SUMMARY BY FAN HEIGHT

Figure 10

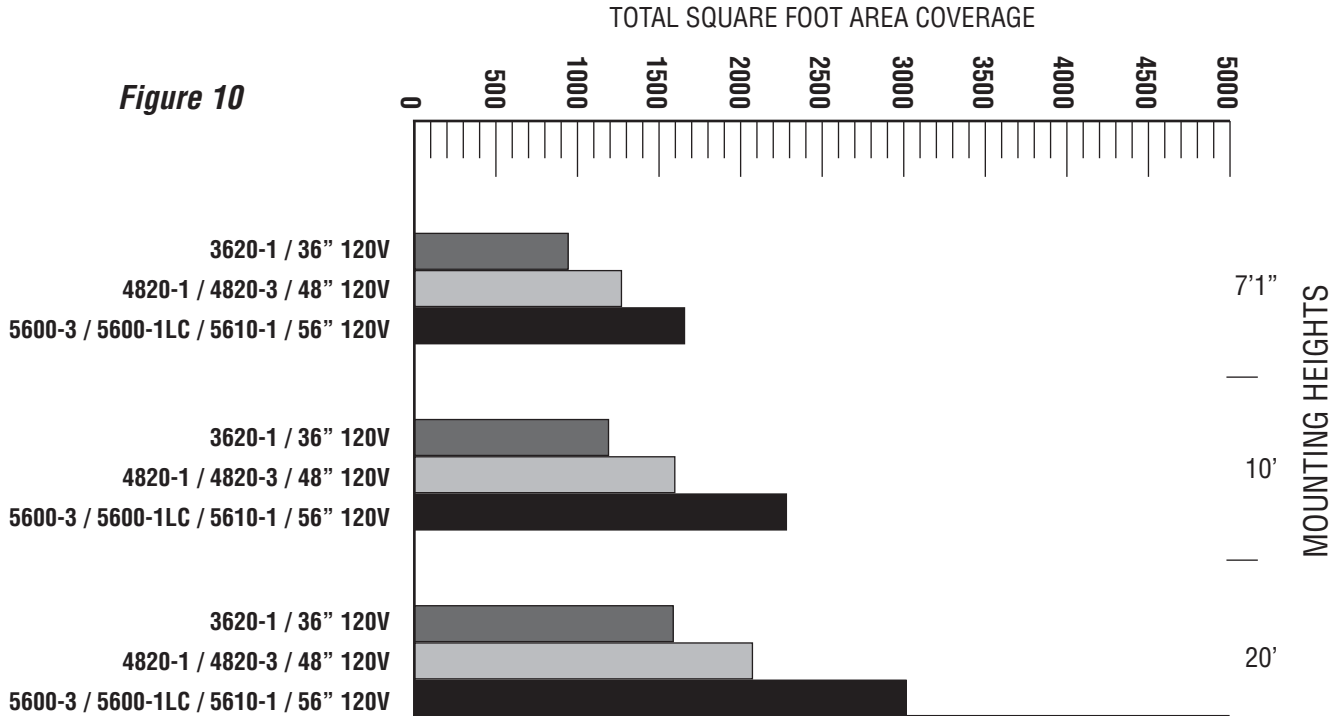

# HEAVY DUTY COMMERCIAL MODELS

## TOTAL AREA COVERAGE TABLE

BLADE HEIGHT FROM FLOOR	3620-1	4820-1 4820-3	5600-1LC 5600-3 5610-1
	<b>COVERAGE IN SQUARE FEET</b>		
20'	1600 Ft. <sup>2</sup> 40' x 40'	2025 Ft. <sup>2</sup> 45' x 45'	3025 Ft. <sup>2</sup> 55' x 55'
10'	1225 Ft. <sup>2</sup> 35' x 35'	1600 Ft. <sup>2</sup> 40' x 40'	2300 Ft. <sup>2</sup> 48' x 48'
7'1"	900 Ft. <sup>2</sup> 30' x 30'	1225 Ft. <sup>2</sup> 35' x 35'	1600 Ft. <sup>2</sup> 40' x 40'

Figure 11

NOTE: Above area coverage calculations are for heat destratification.

# LEADING EDGE HEAVY DUTY INDUSTRIAL CEILING FAN DATA

Maximum Area Coverage at Lowest Total Installed Cost.

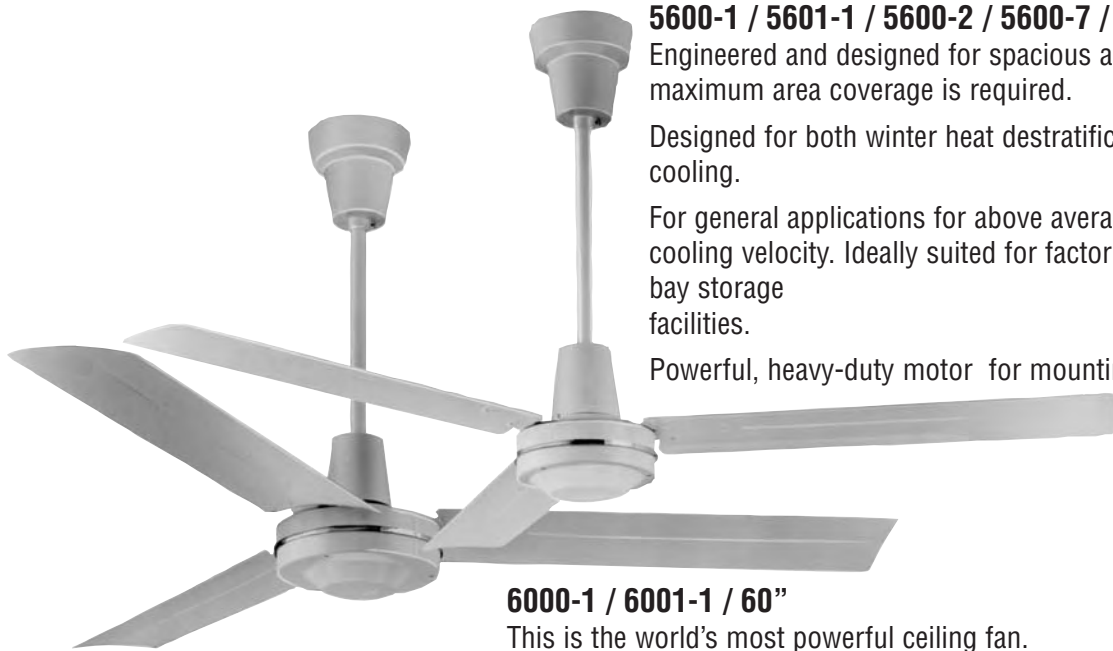

## 5600-1 / 5601-1 / 5600-2 / 5600-7 / 56" Industrial Fans

Engineered and designed for spacious applications where maximum area coverage is required.

Designed for both winter heat destratification and summertime cooling.

For general applications for above average area coverage and cooling velocity. Ideally suited for factories, gymnasiums, high bay storage facilities.

Powerful, heavy-duty motor for mounting heights to 45 feet.



## 6000-1 / 6001-1 / 60"

This is the world's most powerful ceiling fan.

It's massive contoured blade design and high RPM efficiency creates the largest square foot area coverage and cooling effectiveness available.

Capable of heat destratification to heights of 75' or more.



## 5630-1RDP/56" Reversible

The dual pitch blade (Patented), is the only blade designed for maximum reverse direction air flow.

Ideally suited for exhausting, condensation removal and prevention, reverse destratification and other draft free applications.

For industrial applications with mounting heights of 10' or higher.

### HEAVY DUTY INDUSTRIAL MODELS

MODEL NUMBER	BLADE SWEEP	COLOR	VOLTS	CYCLE	FULL LOAD AMPS	FULL LOAD WATTS	RPM	MAX CFM <sup>1</sup>	AREA COVERAGE PER FAN <sup>11</sup>	WEIGHT
5600-1	56"	WHT	120	50/60	1.0	110	275	27,500	3800 sq.ft.	24 lbs
5601-1	56"	BRN	120	50/60	1.0	110	275	27,500	3800 sq.ft.	24 lbs
5600-2	56"	WHT	220	50/60	.52	110	260	26,000	3800 sq.ft.	24 lbs
5600-7	56"	WHT	277	50/60	.60	110	260	26,000	3800 sq.ft.	24 lbs
5630-1RDP**	56"	WHT	120	50/60	1.0	110	275	27,500	3800 sq.ft.	24 lbs
6000-1	60"	WHT	120	50/60	1.4	160	315	46,000	5000 sq.ft.	30 lbs
6001-1	60"	BRN	120	50/60	1.4	160	315	46,000	5000 sq.ft.	30 lbs

\*\*Reversible, includes toggle switch

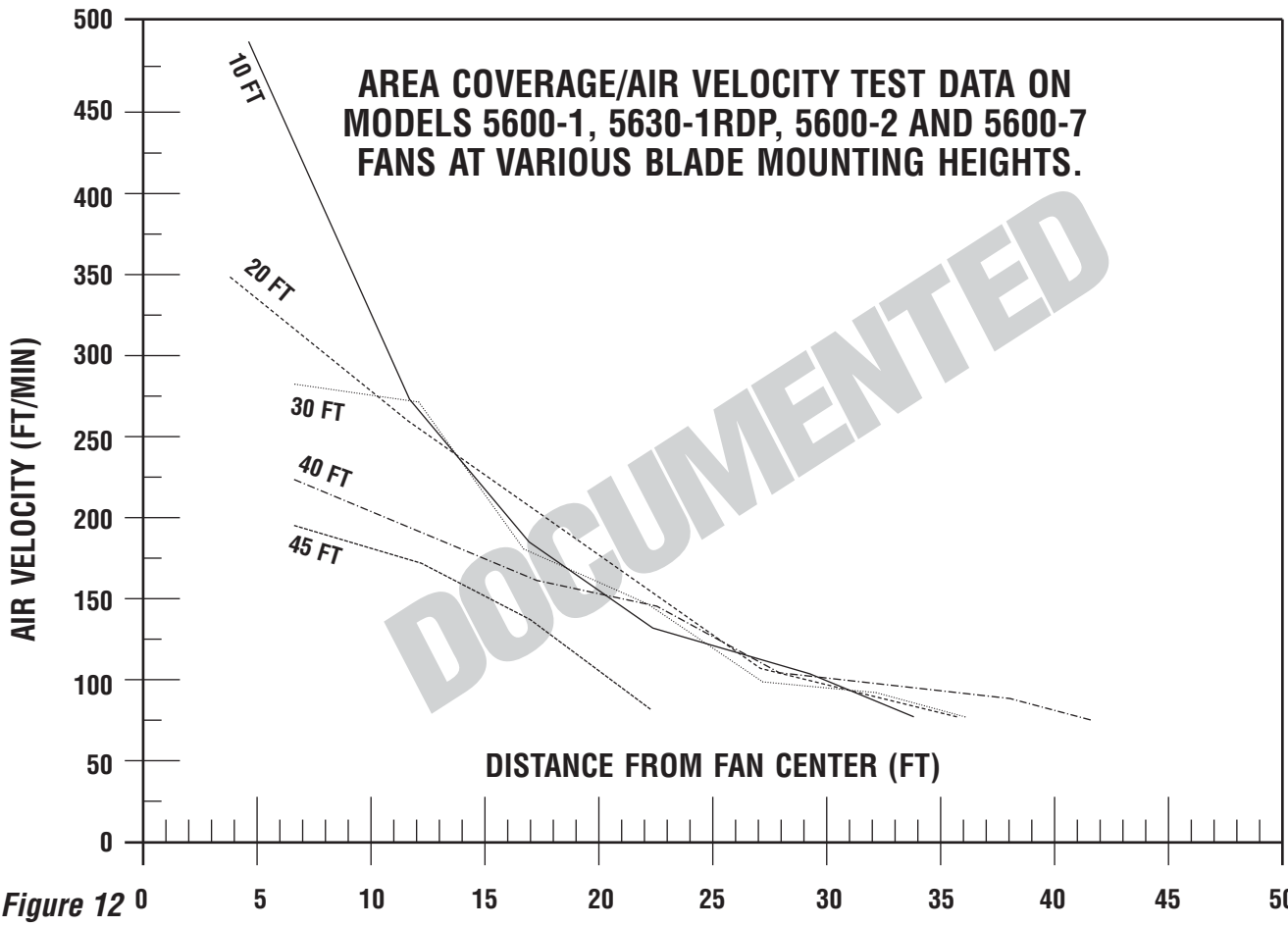

Figure 12

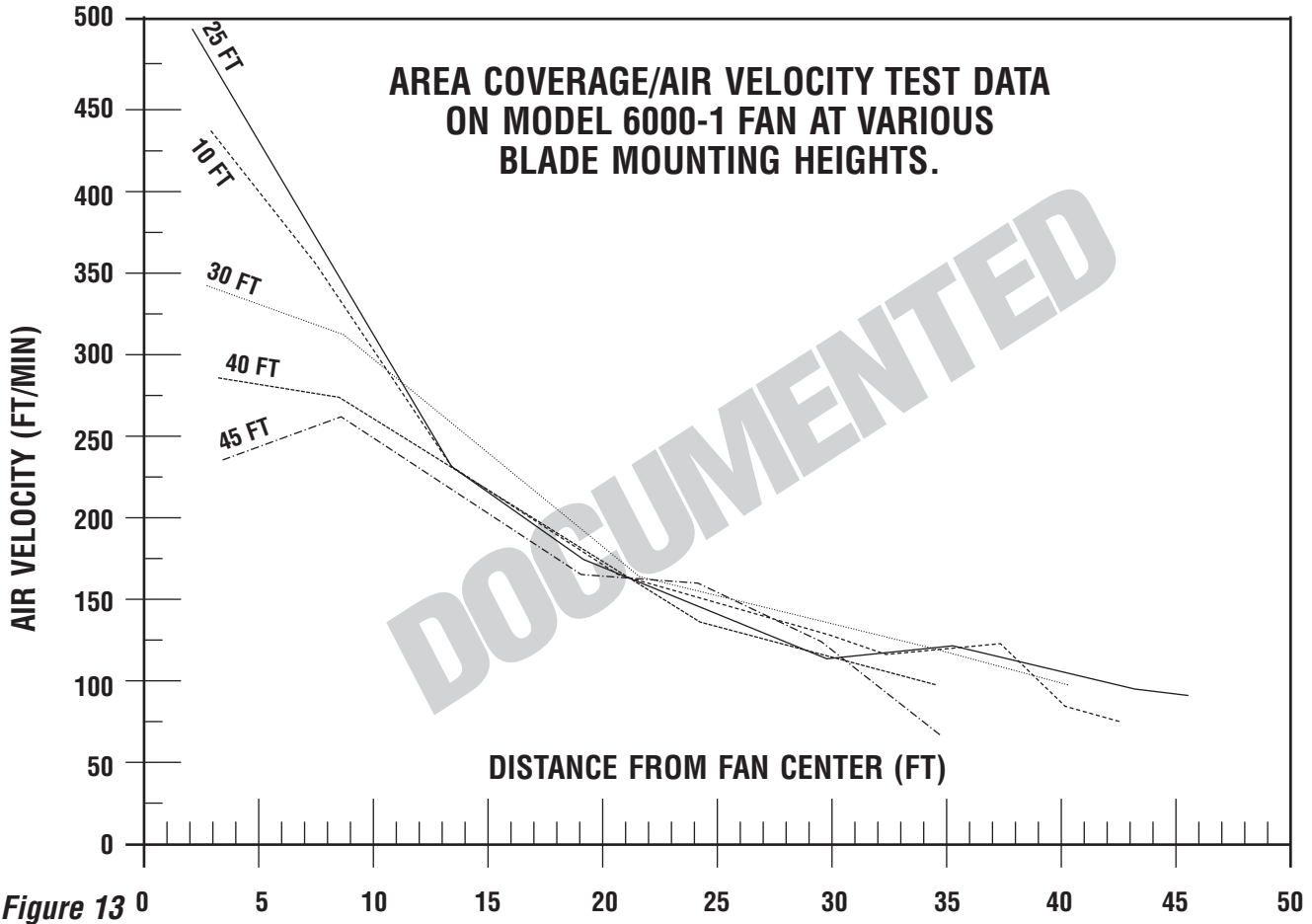
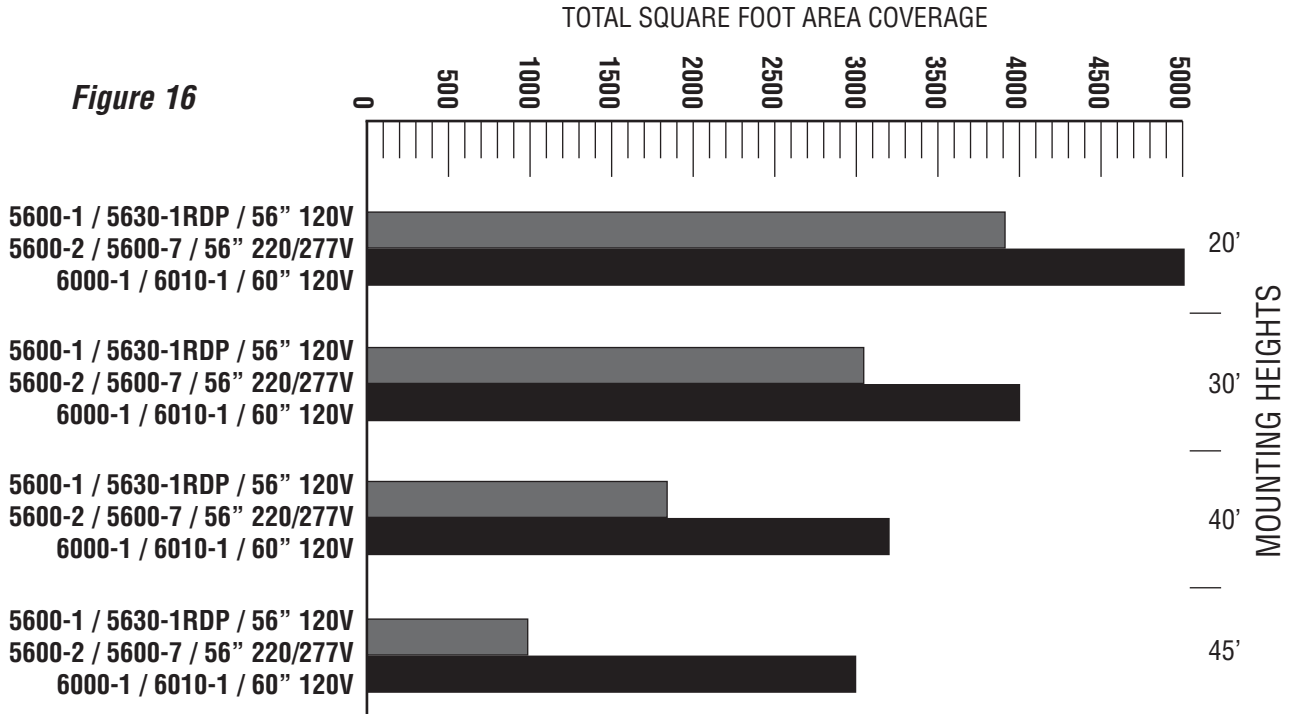

Figure 13

# HEAVY DUTY INDUSTRIAL MODELS

## AREA COVERAGE SUMMARY BY FAN HEIGHT

Figure 16



# HEAVY DUTY INDUSTRIAL MODELS

## TOTAL AREA COVERAGE TABLE

BLADE HEIGHT FROM FLOOR	5600-1, 5600-2 5600-7 5630-1RDP	6000-1 6010-1
	COVERAGE IN SQUARE FEET	
45'	1225 Ft. <sup>2</sup> 35' x 35'	2900 Ft. <sup>2</sup> 54' x 54'
40'	1800 Ft. <sup>2</sup> 42' x 42'	3600 Ft. <sup>2</sup> 60' x 60'
30'	3025 Ft. <sup>2</sup> 55' x 55'	4000 Ft. <sup>2</sup> 63' x 63'
20'	3800 Ft. <sup>2</sup> 62' x 62'	5000 Ft. <sup>2</sup> 71' x 71'

Figure 17

NOTE: Above area coverage calculations are for heat destratification.

# NEW INDUSTRIAL REVERSIBLE FAN WITH EXCLUSIVE PATENTED HIGH PERFORMANCE “DUAL PITCH” BLADE



Finally a fan that provides identical air flow volume, in either forward or reverse rotation.

The dual pitch blade (Patented), is the only blade designed for maximum reverse direction air flow.

Ideally suited for exhausting, condensation removal and prevention, reverse destratification and other draft free applications.

For industrial applications with mounting heights of 10' or higher.

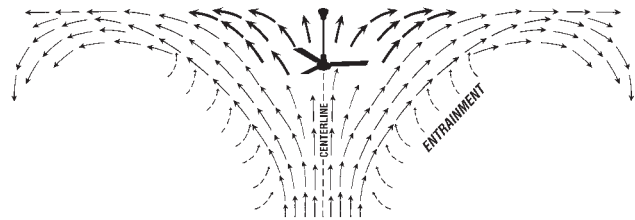
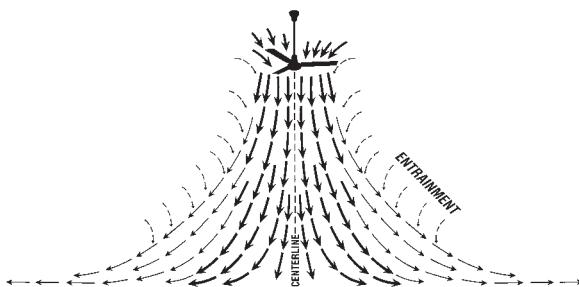
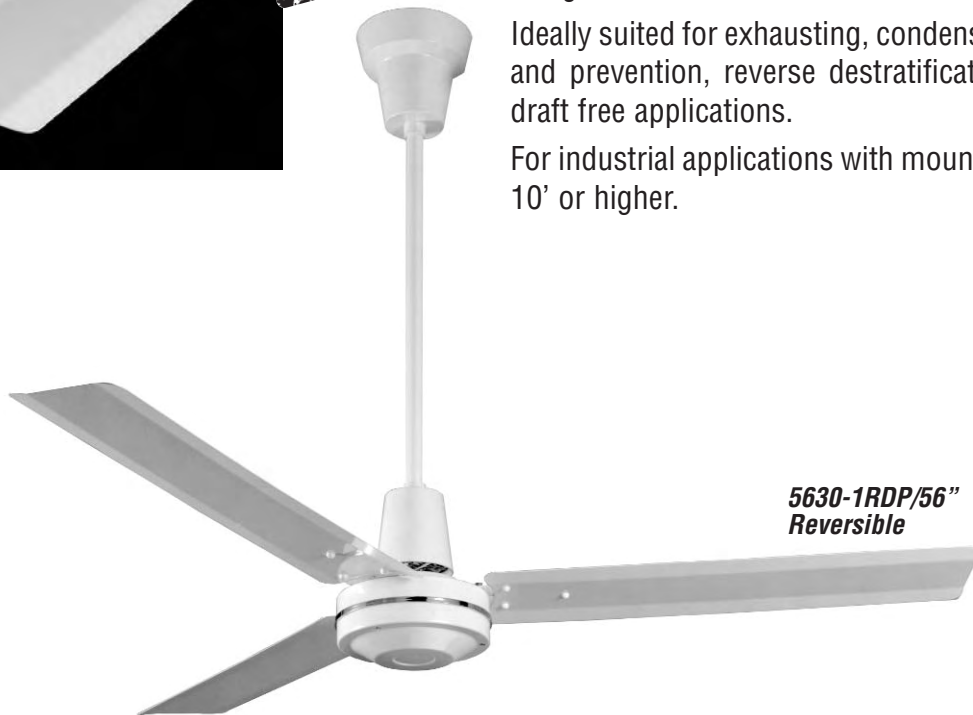

MODEL:	<b>5630-1RDP (Reversible)**</b>		
	<b>120 VOLT 50/60 Hz</b>		
BLADE SWEEP:	<b>56"</b>	<b>Max. CFM: 27,500***</b>	
	AMPS	WATTS	RPM
HIGH SPEED:	1.0	110	275
LOW SPEED:*	.56	45	125

\* Low speed ratings are with optional motor speed controls (See page 32).

\*\* Special application fan.

\*\*\* Effective amount of air volume moved past a plane 20 ft. from fan, industry test.

All specifications subject to change and improvement.

NOTE: 50Hz current produces approximately 5 percent loss of RPM/velocity.

# HARSH ENVIRONMENT CEILING FANS

## PATENTED SPRAYPROOF AND CORROSION RESISTANT INDUSTRIAL MODELS

This line is built using the same proven motors as our heavy-duty industrial fans. All motors are specially modified with our unique sprayproof construction. (Patented)

### FEATURES

- Heat destratification
- Summer cooling
- Moisture control in food processing plants and bottling facilities
- Rust and corrosion prevention
- Condensation control
- Curing purposes
- Smog and fume control

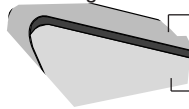

UL 507 states Ceiling Fans suspended from 7 feet to less than 10 feet (blade height to floor) must have minimum thickness of edge of blade 3/16"

### Designed and Engineered Specifically for:

#### Commercial/Industrial Applications

- Food Processing Plants
- Wet Factory Locations
- Indoor Swimming Pool Areas
- Exposed Shipping Areas
- Outdoor Restaurants
- Outdoor Shopping Malls

#### Agricultural Applications

- Poultry Houses
- Hog Sheds
- Dairy Barns
- Green Houses
- Nurseries
- Stables

This unique line (Patented) was also designed for any industrial area having a high content of dirt, dust, contaminants and where steam is present in its atmosphere. These areas include mills, foundries, rubber processing facilities, metal grinding areas, abrasives, etc...

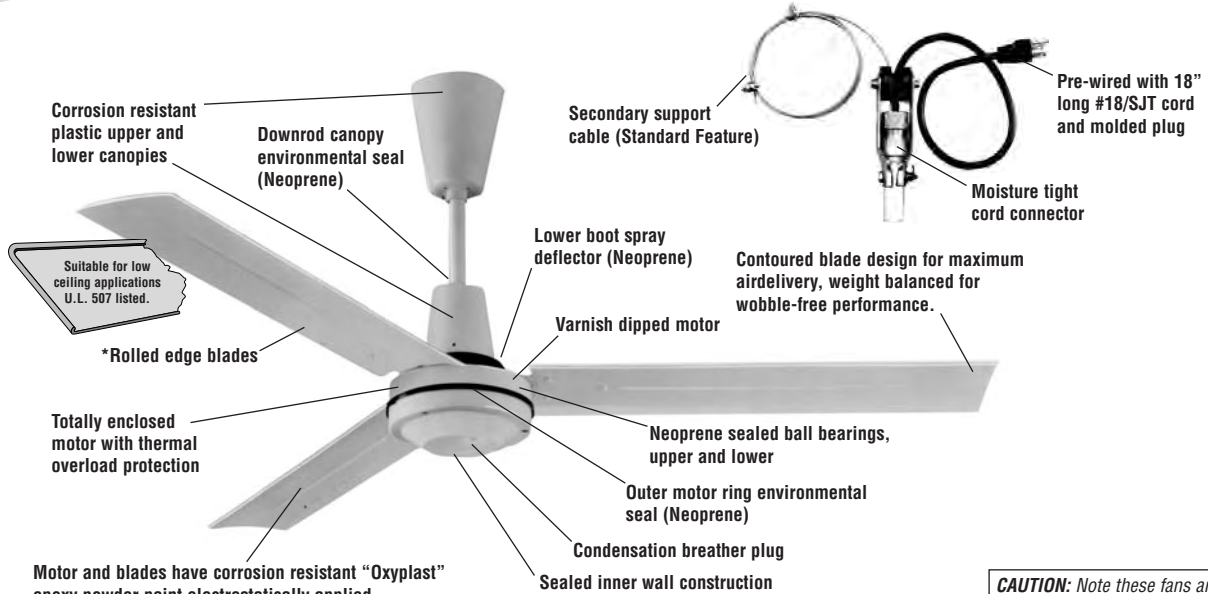

\*The only fan U.L. listed for low ceiling installation.

**CAUTION:** Note these fans are not approved or classified for explosive atmospheres and must not be used in such areas.

## SPECIFICATION & PERFORMANCE DETAILS

MODEL NUMBER	COLOR	SWEEP	VOLTAGE	CYCLE	AMPS	WATTS	RPM	MAX CFM	AREA COVERAGE
5610-1	WHT	56"	120	50/60	1.0/0.56	110/36	265/110	25,500	See Table
6010-1	WHT	60"	120	50/60	1.4/0.75	160/70	280/120	41,000	See Table

Also available in Reversible Model (see page 22).

NOTE: Outdoor application installation requires optional installation kit for outdoor location.

NOTE: 50Hz current produces approximately 5 percent loss of RPM velocity.

For documented Air Coverage/Air Velocity flow charts for these models refer to page 20, figure 9A.

## TOTAL AREA COVERAGE

BLADE HEIGHT FROM FLOOR	5610-1	6010-1
COVERAGE IN SQUARE FEET		
40'	1800 Ft. <sup>2</sup> 42' x 42'	3600 Ft. <sup>2</sup> 60' x 60'
30'	2800 Ft. <sup>2</sup> 53' x 53'	4000 Ft. <sup>2</sup> 63' x 63'
20'	3025 Ft. <sup>2</sup> 55' x 55'	5000 Ft. <sup>2</sup> 71' x 71'
10'	2300 Ft. <sup>2</sup> 48' x 48'	3800 Ft. <sup>2</sup> 62' x 62'
7'	1600 Ft. <sup>2</sup> 40' x 40'	N.T.



U.S. Patent Numbers  
4,592,702 & 5,135,365

Shipped pre-assembled and ready to hang. Simply attach the blades.



**NOTE:** Pre-assembled with 12" downrod

# FAN PLACEMENT CALCULATION

- Refer to the various flow charts and bar graphs in this guide to determine the fan best suited for your building area and ceiling height.
- Compute the total area of your building. Multiply length times width for total square foot area. Prepare a diagram as per **Figure 19**.
- Refer to the summary tables for squared area coverage. Determine the placement and exact quantity of fans required.
- Start your placement from the corner of one section of the building. Example: (**Figure 19**) model 5600-1 at 20 ft. blade mounting height has a 62 ft. x 62 ft. area coverage. The initial placement would be 30 ft. in from the rear wall and 30 ft. in from the side wall. The second fan would be 60 ft. on center from the first, etc...
- This placement process may vary depending on ceiling beam locations, racks, machinery and density of workers. It is permissible to move a fan location within 5 ft. of the recommended placement to accommodate these factors.
- Do not mount fans above racks but rather in the aisles.
- To help prevent cold air infiltration, place fans in the general proximity of frequently used freight doors.
- Place fans above any heat producing equipment to recapture heat.
- Narrow buildings may require additional planning and selection based upon ceiling height.
- Certain commercial models have both 24 inch rods and additional 8 inch rods for low ceiling application. Never mount on a rod less than 8 inches from the ceiling or the intake side of the fan will starve for air.
- All industrial fans are supplied with 24 inch rods which may be shortened, (optional longer rods available). Harsh Environment fans have 12" pre-assembled rods.
- Industrial models must be mounted with minimum blade height 10 ft. from the floor. Certain commercial models may be mounted with minimum blade height of 7 ft. from the floor.

## EXAMPLE BUILDING

240' x 180' = 43,200 square feet

22 ft. clearance height ceiling to floor.

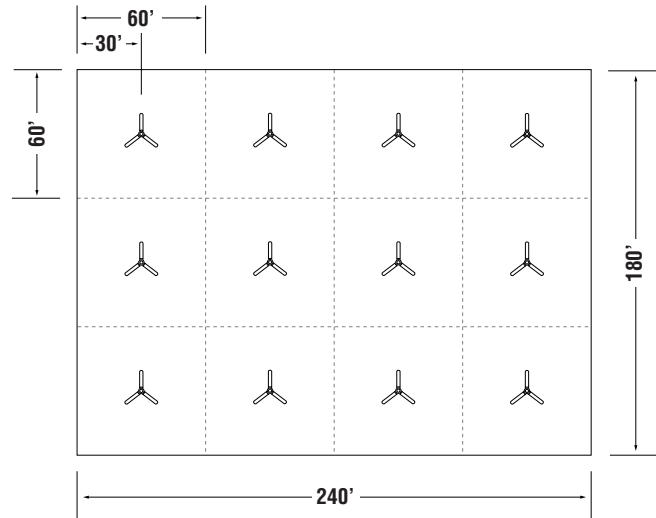

Figure 19

## EXAMPLE WIRING DIAGRAM

240' x 180' = 43,200 square feet

43,200 ft. ÷ 3800 ft. per fan = 12 (5600-1) ceiling fans  
controlled by (3) 6 amp. controls

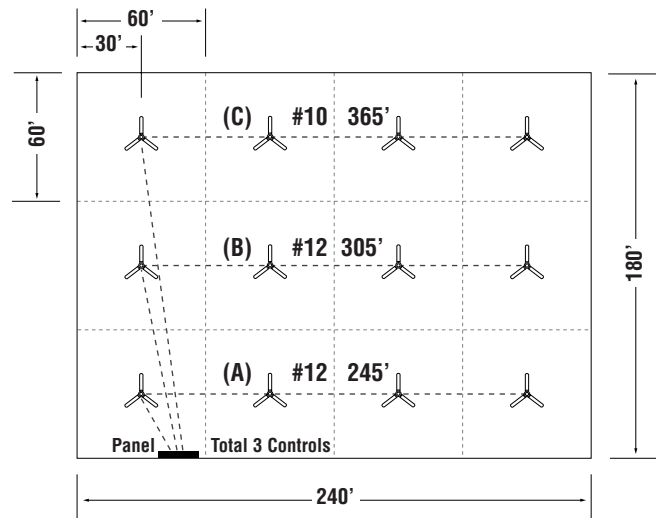

Figure 20

# MOTOR SPEED CONTROLS

## SOLID STATE

All Leading Edge brand infinite motor speed controls were engineered and developed specifically for our own commercial/industrial ceiling fans, based upon our experience in thousands of installations. Our U.L. listed controls were designed to accommodate the heavy-duty criteria of industrial applications. We don't believe in using modified light dimmers to control industrial ceiling fans.

As an example, we replaced the old style 3 Amp. cardboard backed, rangehood type control with an improved model. Our new 3 Amp. control (model 12003) features a finished metal strap mount, 8 Amp. rated triacs and a hard plastic backing to protect the components and circuit board construction.

Our new larger multi-fan controls are constructed

with oversized, insulated tab triacs rated at 400 volts (the highest rated in the industry) as an extra safety factor. These overrated triacs give extra protection to surges in the electrical lines which occur more frequently in industrial environments than in residential use. Larger triacs will add to the longevity of any solid state motor speed control.



Model 12003  
3 Amps



Model 12008  
8 Amps



Model 12012  
12 Amps

### ***Additional features of Leading Edge motor speed controls are:***

- Dial-on/off switch allows high-to-low variable speed control above factory-set "anti-stall" level of 50 v.a.c.
- Dial-on/off switch provides most reliable variable speed control.
- Superior (static-free). RFI -suppression circuitry utilizes a toroid choke with solid copper wire coil.
- Field-adjustable trim control feature allows user to set desired "anti stall" or minimum speed level.

Note: For factory control recommendations and quantity of fans, see control summary Page 32.

*NOTE - When Solid State motor speed controls are used a humming noise is present in all ceiling Fans. This hum in no way effects the operation of the fan and is acceptable in most industrial applications. Where absolute quiet is necessary, see your distributor for optional noiseless mechanical controls.*

## NOISELESS SPEED CONTROLS FOR QUIET AREAS

Our exclusive line of noiseless controls is designed specifically for Leading Edge fans.

Both controls use capacitor value engineering, which avoids the "solid state" humming noise noticeable on low speeds in "quiet areas"

Both fan controls are for use only with models 4820-1, 5600-1 and other 56" Leading Edge models in 120 volt.



Model 12001N  
1 Amps  
For single Fan



Model 12005N  
5 Amps  
For Two Fans

# IMPACT RESISTANT FAN GUARD



## COMPARE THESE FEATURES:

- Totally enclosed for maximum fan protection.
- Mounts directly to fan rod.
- Custom design prevents air-flow interruptions.
- Ships knocked down, packed one per carton, UPS shippable.
- Exclusive “secondary support” cable meets all proposed safety regulations for overhead air movement equipment.

## SPECIFICATIONS:

- Totally enclosed, 52” and 62” diameters.
- Safety cable attachment  $\frac{3}{32}$ ”, 7X7 galvanized aircraft cable 920lbs breaking strength.
- Twelve spoke cross bar construction 5ga. (.207) radial, 5ga. (.207) on 3” centers.
- Heavy duty two piece mounting brace. 16ga. (.062).

---

## “SECONDARY SUPPORT” CABLE

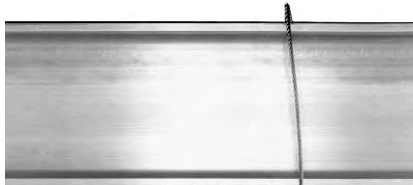

*This new “Secondary Support” cable complies with existing CSA (Canadian Standards Association) requirements and all other other proposed safety regulations for overhead air movement equipment.*

### EXCLUSIVE SHAFT CONNECTION

By attaching directly from the beam to the permanent motor shaft this “Secondary Support” cable protects against any possible failure or improper installation of the fan J hook, upper yoke assembly, rod, lower yoke assembly and related hardware.



### SPECIFICATIONS:

- Pre-installed directly to permanent motor shaft for maximum protection and easy installation.
- 6’ length of heavy-duty 7 x  $\frac{7}{8}$ ” galvanized cable.
- Rated breaking strength of 1700lbs.
- Galvanized U-bolt wire clips (2) included for attachment to beam structure for extra strength and security.
- CSA (Canadian Standards Association) listed (Standard C22.2 Sept 1986).

Leading Edge fans are specifically designed for easy and secure installation. Our exclusive safety cable feature conforms to proposed regulations for secondary support.

# CEILING FAN SUBMITTAL SHEET

NOTE: All measurements are calculated from ceiling or beam line with "J" hook mounted securely in center of 1 1/2" deep conduit box and downrod supplied on rubber roller (See illustration).

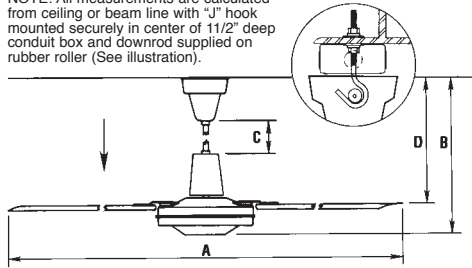

## HEAVY DUTY COMMERCIAL MODELS

MODEL NUMBER	BLADE SWEEP	COLOR	VOLTS	CYCLE	FULL LOAD AMPS	FULL LOAD WATTS	RPM	MAX CFM†	AREA COVERAGE PER FAN††	WEIGHT
3620-1	36"	WHT	120	50/60	.65	75	395	12,500	1600 sq.ft.	20 lbs
4820-1	48"	WHT	120	50/60	.85	86	315	21,000	2025 sq.ft.	22 lbs
5600-1LC	56"	WHT	120	50/60	1.0	110	265	25,500	3025 sq.ft.	24 lbs
CPF56	56"	WHT	120	50/60	1.0	110	265	24,400	3025 sq.ft.	24 lbs
56HRCF	56"	WHT	120	50/60	0.8	96	330	19,800	3025 sq.ft.	24 lbs

## SPECIAL APPLICATION MODELS

4820-1B	48"	BLACK	120	50/60	.85	86	315	21,000	2025 sq.ft.	22 lbs
4820-3*	48"	WHT	120	50/60	.85	86	315	21,000	2025 sq.ft.	23 lbs
5600-1B	56"	BLACK	120	50/60	1.0	110	275	27,500	3800 sq.ft.	24 lbs
5600-3*	56"	WHT	120	50/60	1.0	110	265	25,500	3025 sq.ft.	26 lbs
5630-1RDP**	56"	WHT	120	50/60	1.0	110	275	27,500	3800 sq.ft.	24 lbs

## HARSH ENVIRONMENT MODELS\*\*\*

5610-1	56"	WHT	120	50/60	1.0	110	265	25,500	3025 sq.ft.	24 lbs
6010-1	60"	WHT	120	50/60	6.4	160	280	41,000	5000 sq.ft.	30 lbs

\*3-Speed Pull Chain

\*\*Reversible, includes toggle switch

\*\*\*Requires installation kit for outdoor locations

## HEAVY DUTY INDUSTRIAL MODELS

5600-1	56"	WHT	120	50/60	1.0	110	275	27,500	3800 sq.ft.	24 lbs
5601-1	56"	BRN	120	50/60	1.0	110	275	27,500	3800 sq.ft.	24 lbs
2600-2	56"	WHT	220	50/60	.52	110	260	26,000	3800 sq.ft.	24 lbs
5600-7	56"	WHT	277	50/60	.60	110	260	26,000	3800 sq.ft.	24 lbs
6000-1	60"	WHT	120	50/60	1.4	160	315	46,000	5000 sq.ft.	30 lbs
6001-1	60"	BRN	120	50/60	1.4	160	315	46,000	5000 sq.ft.	30 lbs

## ACCESSORIES & MISCELLANEOUS ITEMS

MODEL NUMBER	ITEM
2800-1	<ul style="list-style-type: none"> <li>FAN GUARD 62" DIAMETER FOR INDUSTRIAL 56" AND 60" FANS ♦</li> <li>FAN GUARD 52" DIAMETER FOR COMMERCIAL 36" AND 48" FAN ONLY ♦</li> <li>TILTED CANOPY COVER</li> <li>DOWNRODS - 8", 12", 24", 30", 36", 48" (FOR LONGER SIZES - CONSULT FACTORY)</li> <li>OUTDOOR LOCATION INSTALLATION KIT</li> </ul>
2800-2	
9999-4	
9999-0	
9999-2	
9999-0	

• Use only with heavy-duty industrial models

♦ Fan Guards ship via UPS

Custom models available. Consult with factory for information and specifications.

## OPTIONAL SOLID STATE MOTOR SPEED CONTROLS

MODEL NUMBER	VOLTS	AMPS	CONTROLS			CONTROLS		CONTROLS	
			36"/120 3620-1 UNITS	48"/120 4820-1 UNITS	56"/120 5600-1 5600-1LC 5630-1RDP 5610-1 UNITS	56" 220/277 5600-2 5600-7 UNITS	60"/120 6000-1 6010-1 UNITS		
12003	120	3	3	2	2			1	
12006	120	6	7	5	5			3	
12008	120	8	10	6	6			4	
12012	120	12	12	10	10			8	
22003	220	3				2			
22008	220	8				6			
22012	220	12				8			
27703	277	3				2			
27708	277	8				6			
27712	277	12				8			

## NOISELESS MECHANICAL CONTROL

12001N	120	1		1	1			For use with 48" and 56" models only.
12005N	120	5		2	2			

3 YEAR WARRANTY REGISTRATION AGAINST MANUFACTURERS DEFECTS IS INCLUDED WITH EACH FAN.

† Effective amount of air volume moved past a plane 20ft. from fan, industry test. All specifications subject to change and improvement.

†† Area coverage rated for heat destratification at 20' blade mounting height.

# LEADING EDGE COMMERCIAL/INDUSTRIAL CEILING FAN SPECIFICATIONS

## TYPICAL SPECIFICATIONS

Ceiling Fans to be furnished as specified, Leading Edge. Fans to be U.L. listed Standard 507 with matching U.L. listed solid state controls. All motors to be direct-drive permanent split capacitor type, with permanently sealed ball bearings. All motors to have built in, self-resetting (internal) thermal overload protector TI9700.

Fan Model \_\_\_\_\_, Blade Diameter (sweep) \_\_\_\_\_, Primary Voltage \_\_\_\_\_, motor to be totally enclosed, Full Speed Watts to be \_\_\_\_\_, RPM to be \_\_\_\_\_, CFM to be \_\_\_\_\_, and Area Coverage per Fan to be \_\_\_\_\_ Sq. Ft. Performance shall be certified by AMCA, an independent test laboratory or a University Engineering department with documented testing.

All fans to have factory installed Secondary Support Cable Assembly connected to motor shaft, with minimum 6 feet galvanized cable  $\frac{1}{8}$ " 7x7 with rated breaking strength of 1700 lbs. and must comply with CSA std. C22.2 Sept. 1986.

Fan blades to be straight with contoured shaped design for maximum efficiency. Note: Fans installed with blade height less than 10' from floor must have rolled edge blades minimum  $\frac{3}{8}$ " thick in compliance with U.L. 507.

Fans to be labeled in accordance with U.L. 507 "Mounted blade height to floor of 7 feet acceptable".

Fans used with motor speed controls must be labeled in accordance with U.L. 507 "Suitable for use with solid state motor speed controls".

Factory supplied accessories to include:

- A) Solid state motor speed controls (U.L. listed)
- B) Special length downrods
- C) Totally enclosed impact resistant fan guard
- D) Tilted canopy cover

CEILING FAN DIMENSIONS*				
MODEL SERIES	A	MODELS SUPPLIED WITH 24" DOWNROD		
		B	C	D
3620-1***	36"	33 $\frac{1}{2}$ "	19"	30 $\frac{1}{2}$ "
4820-1***	48"	33 $\frac{1}{2}$ "	19"	30 $\frac{1}{2}$ "
4820-3***	48"	35 $\frac{1}{2}$ "	19"	30 $\frac{1}{2}$ "
5600-1LC***	56"	33 $\frac{1}{2}$ "	19"	30 $\frac{1}{2}$ "
5600-3***	56"	35 $\frac{1}{2}$ "	19"	30 $\frac{1}{2}$ "
5630-1RDP	56"	33 $\frac{1}{2}$ "	19"	30 $\frac{1}{2}$ "
5600-1**	56"	33 $\frac{1}{2}$ "	19"	30 $\frac{1}{2}$ "
6000-1	60"	34"	19"	30 $\frac{3}{4}$ "
MODELS SUPPLIED WITH 12" DOWNROD				
5610-1	56"	21 $\frac{3}{4}$ "	5 $\frac{1}{2}$ "	18 $\frac{1}{2}$ "
6010-1	60"	22"	5 $\frac{3}{4}$ "	18 $\frac{1}{2}$ "

NOTE: All measurements are calculated from ceiling or beam line with "J" hook mounted securely in center of  $\frac{1}{2}$ " deep conduit box and downrod supplied on rubber roller (See illustration).

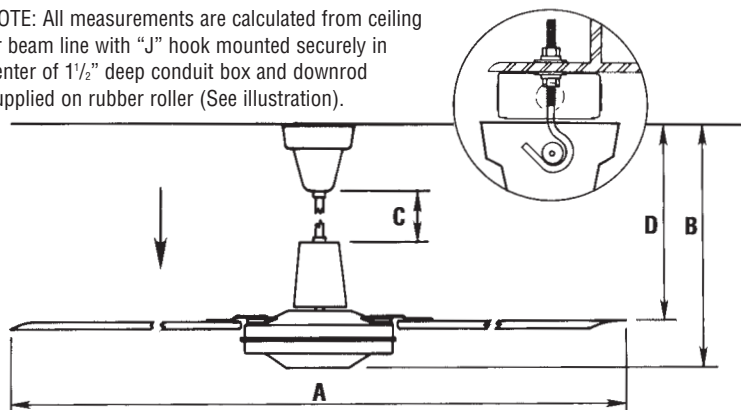

\* Allow for 1/2" variance in "J" hook depth.  
 \*\* Identical measurements for 220 volt and 277 volt models.  
 \*\*\* Note for models supplied with shorter 8" downrod subtract 13" from measurement scale "C".

# LEADING EDGE...

Founded during the energy crisis of the 70's, Leading Edge pioneered the concept of heat destratification by developing the market's largest, most powerful line of industrial ceiling fans. We have grown to become the recognized specialist in three key commercial and industrial product categories:

## ***Ceiling Fans***

As the world's largest commercial/industrial ceiling fan manufacturer, we offer the most comprehensive model line-up in all-world voltages. We have the only fans with exclusive documented area coverage performance data. Our unique blade and motor designs have earned us several United States Patents.

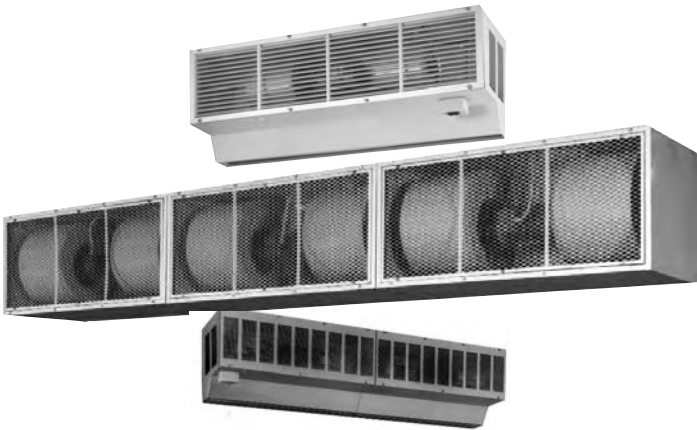

## ***Environmental-Air-Curtains***

We offer one of the most extensive model line-ups in the industry, catering to seven separate market requirements. Our patented product design has been rated #1 in air velocity uniformity by Independent Test Laboratories-proof of our industry leadership position.

## ***Air Circulators***

Recognized for premium quality and high performance, Leading Edge air circulators provide outstanding air delivery and durability when used for cooling and ventilating large areas such as factories, warehouses, gymnasiums and public facilities.



By concentrating on these three niche products, we have grown to become a leading supplier of specialized ventilation products. Our reputation for high-quality, extensive model offerings and comprehensive product knowledge has earned us worldwide prominence and distribution. More than two-thirds of America's Fortune 500\* companies use and specify Leading Edge products. We value this acceptance which has allowed us to continue increasing our product line to meet your needs in the next decade.

\*For complete listing contact factory.

**AIR  
CIRCULATORS**



*Additional products  
available from  
Leading Edge*



**ELECTRIC  
HEATERS**



**AIR CURTAINS**

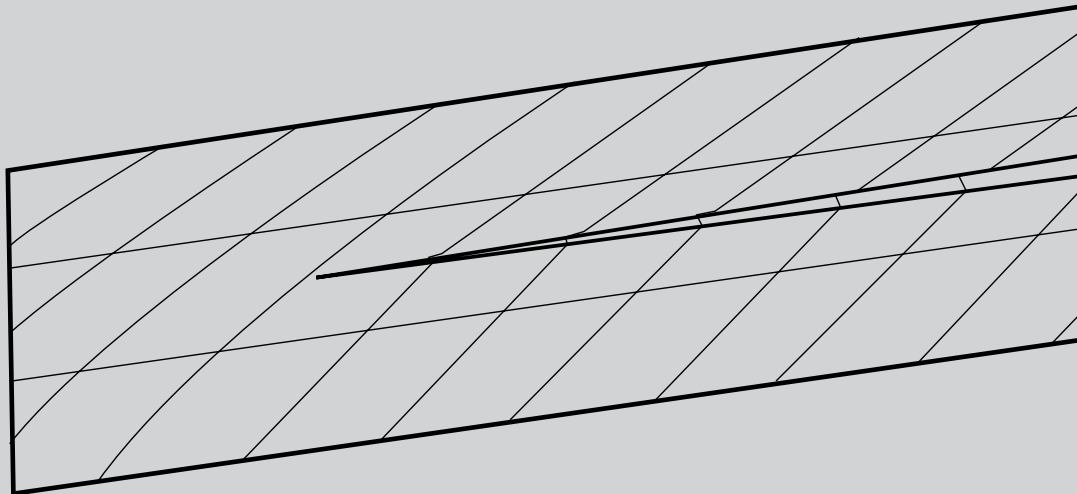
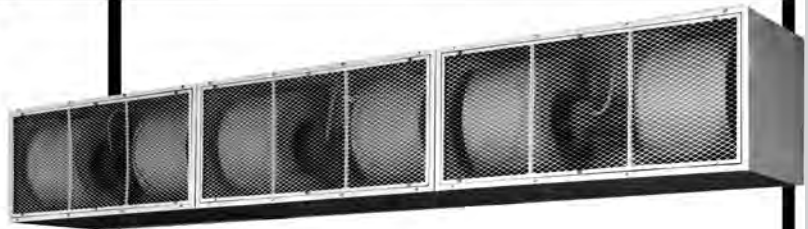

470 Beauty Spot Road East  
Bennettsville, SC 29512  
Phone: (843) 479-4006

Distributed By:

Form Number: ZDA-LEFTG